



# Linux\* Stacks for Intel® Trust Domain Extension 1.0

v0.11

August 2023

Document Number: 355388-001

# Contents

1	Introduction.....	8
1.1	Overview.....	8
1.2	Terminology .....	11
2	Install.....	13
2.1	Hardware.....	13
2.2	BIOS.....	14
2.3	Components.....	16
2.4	Building Stacks .....	18
2.4.1	Build Packages.....	18
2.4.2	Create Guest Image .....	20
2.5	Install IaaS Host.....	22
2.5.1	Install Packages by Manual.....	23
2.5.2	Deploy via Ansible.....	24
2.5.3	Reboot with the Intel TDX kernel .....	26
3	Manage the TD guest .....	27
3.1	Overview.....	27
3.2	Boot TD Guest.....	31
3.2.1	Launch via QEMU.....	31
3.2.2	Launch via Libvirt .....	33
3.3	Secure Boot.....	34
3.4	Use VirtIO Device .....	37
3.5	Full Disk Encryption .....	39
3.5.1	Workflow.....	39
3.5.2	Prepare Encryption Image.....	41
4	Measurement & Attestation .....	42
4.1	TEE, TCB, Quote.....	42
4.2	TDX Measurement.....	43

4.2.1	TD Report.....	43
4.2.2	MRTD and RTMR.....	43
4.2.3	Pre-Boot Measurement.....	44
4.2.4	PyTdxMeasure Tool.....	45
4.2.5	Linux Runtime Measurement .....	46
4.3	Attestation.....	47
4.3.1	Overview.....	47
4.3.2	Set Up DCAP Repository on Host .....	49
4.3.3	Set Up PCCS on Host.....	50
4.3.4	Set Up Quote Generation Service on Host .....	52
4.3.5	Generate Quote in TD.....	54
4.3.6	Verify TD Quote on Host .....	56
4.4	Use Intel Project Amber .....	58
4.4.1	Overview.....	58
4.4.2	Installation .....	58
4.4.3	Example Usage .....	59
5	Validation .....	61
5.1	Overview.....	61
5.2	PyCloudStack .....	62
5.2.1	Overview.....	62
5.2.2	Installation .....	64
5.2.3	Example.....	64
5.3	Intel TDX Tests.....	66
5.3.1	Overview.....	66
5.3.2	Prerequisites.....	68
5.3.3	Setup Environment .....	69
5.3.4	Run Tests.....	70
6	Develop & Debug.....	72
6.1	Override the Intel TDX module.....	72

6.2	Off-TD Debug via GDB from the Host .....	74
6.3	Check Memory Encryption .....	76
6.4	Run Intel AMX workload within TDX Guest.....	77
7	Disclaimer .....	80
8	References.....	82

# Figures

FIGURE 1: INTEL® TDX.....	8
FIGURE 2: INTEL TDX COMPONENT INTERFACES .....	9
FIGURE 3: LINUX STACK FOR INTEL TDX .....	10
FIGURE 4: 8+0 DIMM POPULATION FOR INTEL TDX.....	13
FIGURE 5: 16+0 DIMM POPULATION FOR INTEL TDX.....	14
FIGURE 6: BIOS SETTINGS FOR INTEL TDX .....	15
FIGURE 7: LINUX STACK FOR INTEL TDX OVERVIEW .....	16
FIGURE 8: END-TO-END HOST AND GUEST STACK FOR LINUX AND INTEL TDX.....	18
FIGURE 9: BUILD PROCESS FOR INTEL TDX PACKAGES .....	19
FIGURE 11: CREATE INTEL TDX UBUNTU GUEST IMAGE .....	21
FIGURE 10: CREATE INTEL TDX RHEL GUEST IMAGE .....	22
FIGURE 12: DEPLOY TDX HOST STACK VIA ANSIBLE .....	25
FIGURE 13: TD GUEST BOOT PROCESS.....	27
FIGURE 14: DETAILED BOOT FLOW FOR DIFFERENT TD BOOT.....	29
FIGURE 15: ENABLE SECURE BOOT .....	34
FIGURE 16: TDX GUEST ATTACK SURFACE .....	38
FIGURE 17: FULL DISK ENCRYPTION IN TDX GUEST .....	39
FIGURE 18: MEASUREMENT AND ATTESTATION FOR TEE.....	42
FIGURE 19: INTEL TDX MEASUREMENT .....	43
FIGURE 20: TD MEASUREMENT PROCESS .....	45
FIGURE 21: ENABLE IMA EXTEND HASH TO RTMR .....	46
FIGURE 22: INTEL TDX ATTESTATION FLOW .....	49
FIGURE 23: SETUP PCCS .....	51
FIGURE 24: SET UP DCAP SOFTWARE ON THE TDX HOST.....	53
FIGURE 25: QUOTE GENERATION.....	54
FIGURE 26: APPROACHES TO GENERATE INTEL TDX QUOTE .....	55
FIGURE 27: VERIFY QUOTE.....	57
FIGURE 28: INTEL TDX E2E FULL STACK VALIDATION .....	61
FIGURE 29: PYCLOUDSTACK FRAMEWORK .....	62
FIGURE 30: VALIDATION SCENARIOS FOR VMM AND LIBVIRT .....	63
FIGURE 31: ABSTRACT COMMON OPERATIONS FOR CLOUD STACK.....	63
FIGURE 32: BIOS SEARCH TDX MODULE FROM ESP.....	72
FIGURE 33: OFF-TD DEBUG VIA GDB.....	74

# TABLES

TABLE 1: INTEL TDX BIOS CONFIGURATIONS.....	15
TABLE 2: LINUX STACK FOR INTEL TDX COMPONENTS.....	16
TABLE 3: BOOT TYPES FOR TD GUEST .....	28
TABLE 4: START-QEMU.SH PARAMETERS .....	31
TABLE 5: RTMR DEFINITIONS.....	44
TABLE 6: LINUX STACK FOR INTEL TDX VALIDATIONS .....	61
TABLE 7: TDX STACK TESTS.....	66

## Revision History

Revision Number	Description	Date
0.8	Initial Release	1 <sup>st</sup> May 2023
0.9	<ul style="list-style-type: none"> <li>• Add the reference tool of check-tdx-host.sh</li> <li>• Add chapter 4.2.5 Linux Runtime Measurement via IMA (Linux Integrity Measurement Architecture)</li> <li>• Add chapter 3.5 Full Disk Encryption</li> <li>• Add chapter 4.4 Use Intel Project Amber</li> <li>• Complete the incomplete steps for Secure boot</li> <li>• Add chapter 6.3 Check Memory Encryption</li> </ul>	27 <sup>th</sup> May 2023
0.10	<ul style="list-style-type: none"> <li>• Use \$ for all command code</li> <li>• Normalize the "sudo" usage, use "sudo su" and simple root access used in multiple steps</li> <li>• Add more terminology like TCG, PCR, VMM, etc</li> <li>• Refine the build step for individual package build and full repo build</li> <li>• Update the new "Ubuntu Guest Image" tool</li> <li>• Add ansible deployment tool</li> </ul>	27 <sup>th</sup> June 2023
0.11	<ul style="list-style-type: none"> <li>• Update BIOS settings</li> <li>• Add a note about Amber client packages installation</li> <li>• Adjust manual installation section to include grub config and default kernel setting</li> <li>• Update guest image tool section</li> <li>• Update description of Remote attestation</li> <li>• Add more terminology like QVL, QvE</li> <li>• Fix typo</li> </ul>	11 <sup>th</sup> August 2023

# 1 Introduction

## 1.1 Overview

Intel® Trust Domain Extension (Intel® TDX) refers to an Intel technology that extends virtual machine extensions (VMX) and Intel® Total Memory Encryption – Multi-Key (Intel® TME-MK) with a new kind of virtual machine guest called a trust domain (TD). A TD runs in a CPU mode that is designed to protect the confidentiality of its memory contents and its CPU state from any other software, including the hosting virtual machine monitor (VMM) [1]

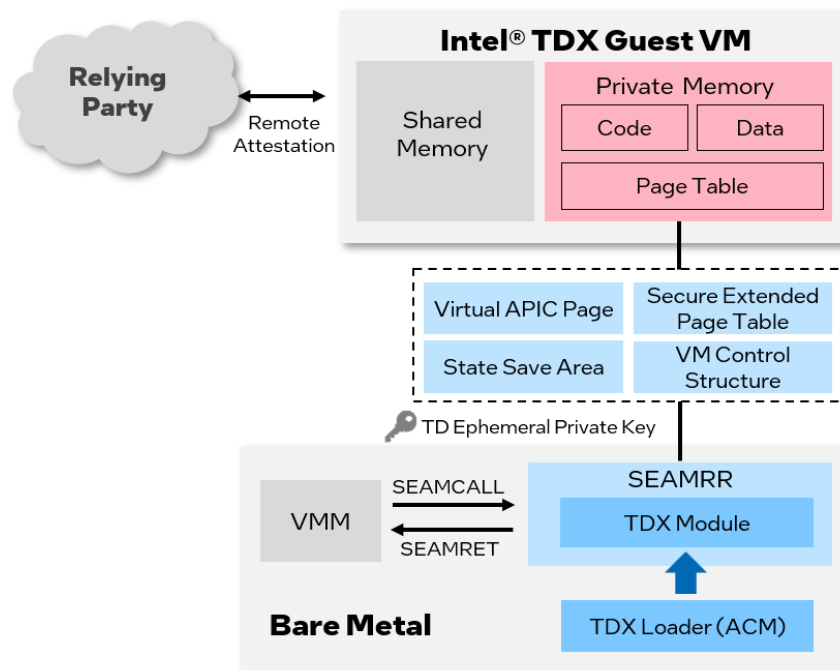

Figure 1: Intel® TDX

The white paper or specifications for Intel TDX can be found at [Intel® Trust Domain Extensions](#), the major components interfaces are defined in the specifications in Figure 2: : Intel TDX Component Interfaces.



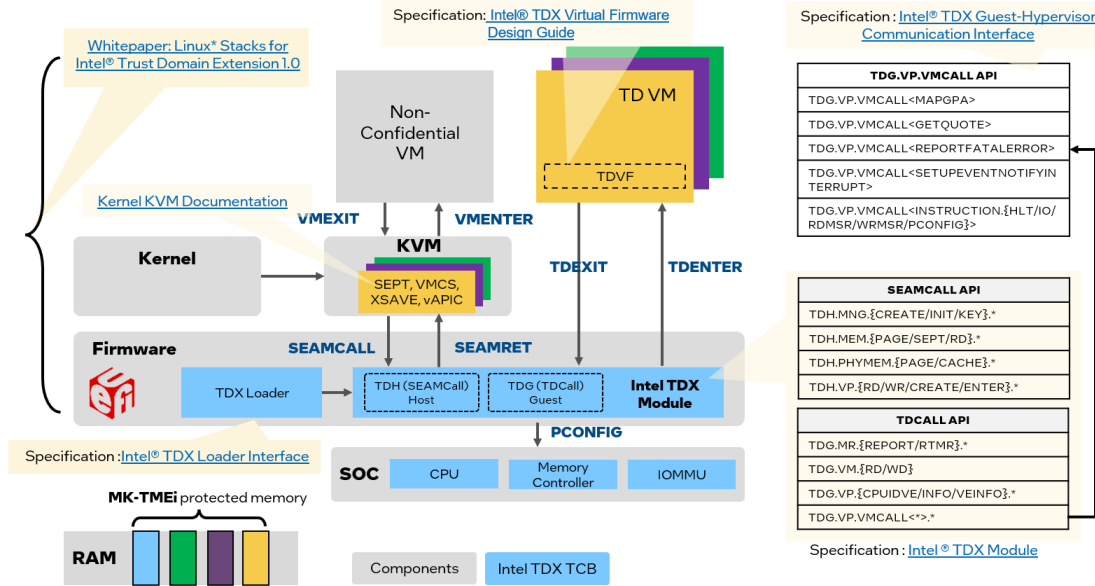

Figure 2: Intel TDX Component Interfaces

Linux\* Stacks for Intel® TDX is an end-to-end hypervisor cloud stack including the Infrastructure as a Service (IaaS) and Platform as a Service (PaaS) components to produce the following minimal use cases:

- Launch Intel® TDX guest VM to run general computing workloads.
- Do launch-time measurement within the Intel® TDX guest VM.
- Do runtime attestation with the quote generated by Intel® Software Guard Extensions (Intel® SGX)-based quote generation service (QGS) on the IaaS host.

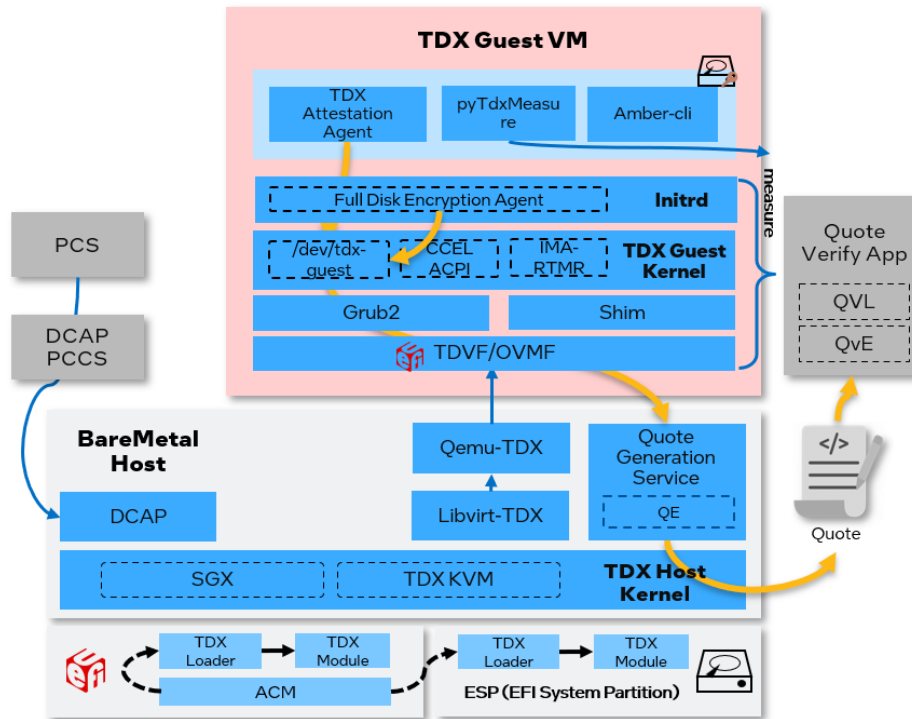

Figure 3: Linux Stack for Intel TDX

The open-source code for Linux Stack for Intel TDX can be found at:

<https://github.com/intel/tdx-tools>.

*NOTE: tdx-tools has multiple release [tags](#). Please make sure to use the correct release tag which matches the release version. The Release tag and kernel version mapping can be found in [tdx-tools wiki](#).*

This document introduces:

- The deployment, cloud stack test, and other common uses for those who want to validate confidential workloads or tune performance.
- The debug and development methods for those who want to integrate stack in their IaaS/PaaS framework.

The OS supported in the document are Ubuntu 22.04 and RHEL 8.7.

## 1.2 Terminology

TERM	DESCRIPTION
ACM	Authenticated Code Module
CFV	Configuration Firmware Volume
CMR	Convertible Memory Ranges
CPLD	Complex Programmable Logic Device
CRB	Customer Reference Board
DCAP	Data Center Attestation Primitives
DIMM	Dual In-line Memory Module
ECC	Error Correction Code memory
ESP	EFI System Partition
FV	Firmware Volume
GPA	Guest Physical Address
GVA	Guest Virtual Address
HVC	Hypervisor Virtual Console
IFWI	Integrated Firmware Image
IBV	Independent BIOS Vendor
Intel SGX	Intel® Software Guard Extensions (Intel® SGX)
Intel TDX	Intel® Trust Domain Extension (Intel® TDX)
LIV server	Live server is used for attestation with production CPU SKUs
LUKS	Linux Unified Key Setup
MOK	Machine Owner Key
MRTD	Measurement of Trust Domain Firmware
OVMF	Open-source Virtual Machine Firmware
PCR	Platform Configuration Register
PCS	Provisioning Certification Service
PCCS	Provisioning Certificate Caching Service
PK/KEK/DB	Platform Key/Key Exchange Key/Database Key
QGS	Quote Generation Service
QMP	QEMU Monitor Protocol
QVE	Quote Verification Enclave
QVL	Quote Verification Library
RTMR	Runtime Measurement Register
SBX server	Sandbox server is used for attestation with pre-production CPU SKUs
SEAM	Secure Arbitration Mode
SVN	Security Version Number

<b>TCB</b>	Trusted-Computing Base
<b>TCG</b>	Trusted Computing Group
<b>TDVF</b>	Trusted Domain Virtual Firmware
<b>TDVM</b>	A TD guest VM
<b>TDX-CI</b>	TDX Crypto Integrity
<b>TDX-LI</b>	TDX Logical Integrity
<b>TEE</b>	Trusted Execution Environment
<b>VMM</b>	Virtual Machine Monitor

## 2 Install

### 2.1 Hardware

Linux Stacks for Intel TDX needs the following hardware support that enables Intel TDX:

- CPU Processor SKU. Contact Intel sales representative for details.
- Board configurations via hardware jumper or CPLD (complex programmable logic device). Contact your ODM/OEM vendor.
- DDR5 DIMM with the type of 10 × 4 ECC (error correction code memory)
- DDR5 RDIMMs with integrity protection.
- DIMM (Dual in-line memory module) population: It is recommended that all channel 0 slots have at least 1 DIMM populated. There are a total of 8 DIMMs per socket. DIMM population must be symmetric across the integrated memory controllers.

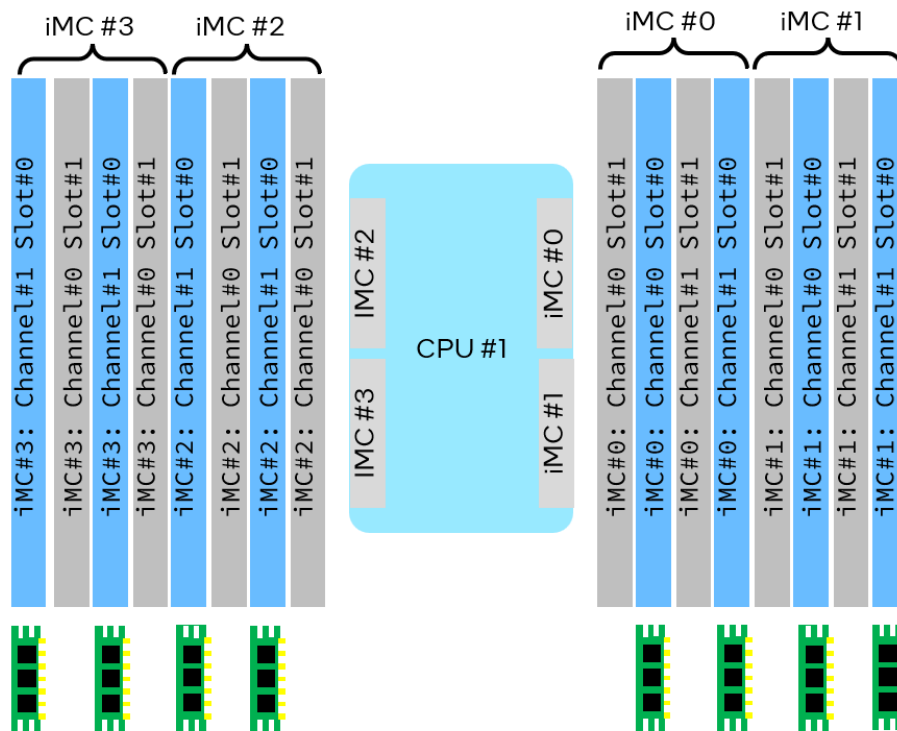

Figure 4: 8+0 DIMM Population for Intel TDX

Intel TDX also supports the full DIMM population 16+0 as follows:

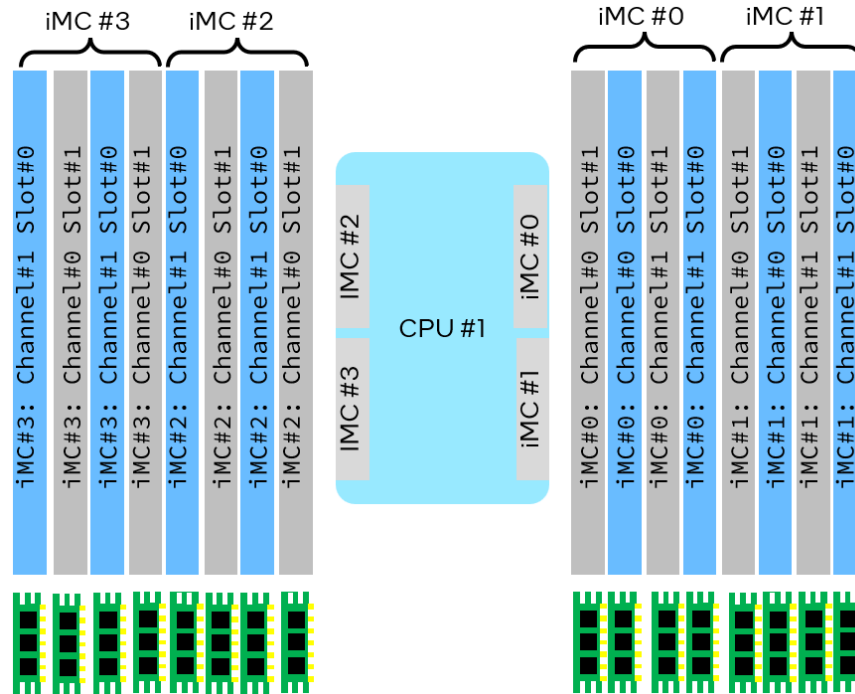

Figure 5: 16+0 DIMM Population for Intel TDX

## 2.2 BIOS

BIOS configurations are needed to support Intel TDX. Contact an Intel sales representative or IBV (independent BIOS vendor) for details. The following settings are examples for reference.

*NOTE: Below diagram is just an example. The configuration or the menus might be different on your BIOS. Contact the IBV or OEM/ODM for the correct settings.*

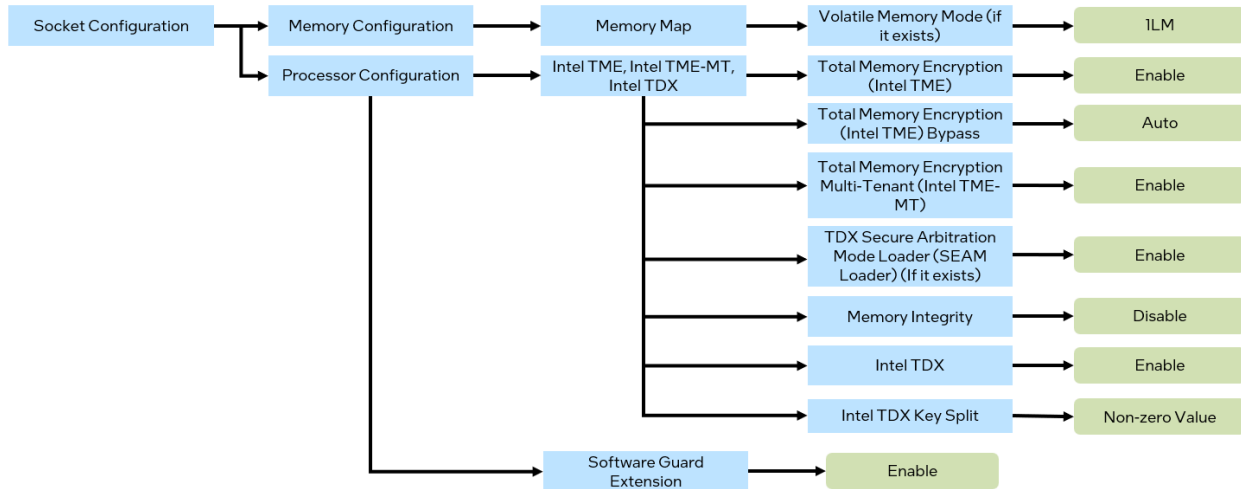

Figure 6: BIOS settings for Intel TDX

Table 1: Intel TDX BIOS Configurations

BIOS Setting	Notes
<b>Volatile Memory = ILM</b>	Intel TDX and CMR (Convertible Memory Ranges) logical integrity, isolation, and cryptographic integrity are only available with directly attached DDR5 memory. <i>NOTE: Please skip this setting if it doesn't exist in BIOS menu.</i>
<b>Total Memory Encryption (Intel TME) = Enable</b>	Intel TDX technology depends on Intel® Total Memory Encryption (Intel® TME).
<b>Total Memory Encryption (Intel TME) Bypass = Auto</b>	4th generation Intel Xeon Scalable processors introduce an Intel TME bypass mode to allow memory outside of Intel TME multi-tenant virtual machines, Intel SGX enclaves, and Intel TDX trust domains to be unencrypted to improve the performance of nonconfidential software.
<b>Total Memory Encryption Multi-Tenant (TME-MT) = Enable</b>	128 Intel TME – Multi-Tenant encryption keys.
<b>TDX Secure Arbitration Mode Loader (SEAM Loader)</b>	Loading Intel TDX module from BIOS when it's enabled.
<b>Memory Integrity = Disable</b>	4th generation Intel Xeon Scalable processor E-stepping does not support Intel TDX-CI, but only supports Intel TDX-LI.
<b>Intel TDX = Enable</b>	Intel TDX should be enabled.

TDX Key Split = <Non-zero Value)	Keys split between Intel TME multi-tenant and Intel TDX.
Software Guard Extension = Enable	Intel TDX depends on Intel SGX technology for hardware TCB and remote attestation.

## 2.3 Components

Linux Stack for Intel TDX is a vertical end-to-end stack including a series of components which are listed in Table 2: Linux Stack for Intel TDX Components

Table 2: Linux Stack for Intel TDX Components.

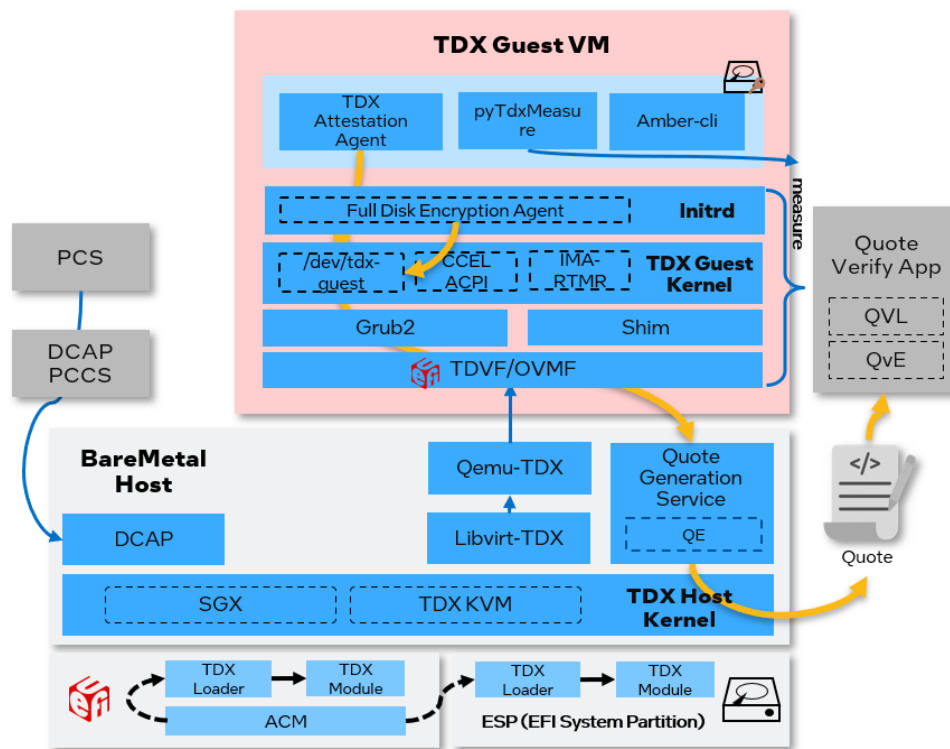

Figure 7: Linux Stack for Intel TDX overview

There are multiple components in the Linux stack for both the host and guest.

Table 2: Linux Stack for Intel TDX Components



Components	Description	Source
Intel TDX Module	An attested software module running in SEAM Root Mode.	<a href="#">Intel Trust Domain Extensions</a>
TDX Loader	A SEAM module intended to install an Intel TDX module into SEAM range.	<a href="#">Intel Trust Domain Extensions</a>
Intel TDX Host Kernel	The host kernel with Intel TDX patches being upstreamed.	<a href="https://github.com/intel/tdx/tree/kvm">https://github.com/intel/tdx/tree/kvm</a>
Intel TDX QEMU	QEMU with Intel TDX patches being upstreamed.	<a href="https://github.com/intel/qemu-tdx">https://github.com/intel/qemu-tdx</a>
Intel TDX Libvirt	Libvirt with Intel TDX patches being upstreamed.	<a href="https://github.com/intel/libvirt-tdx/tree/for_QEMU_upstream">https://github.com/intel/libvirt-tdx/tree/for_QEMU_upstream</a>
TDVF	Virtual firmware (aka OVMF) with Intel TDX features already upstreamed.	<a href="https://github.com/tianocore/edk2">https://github.com/tianocore/edk2</a>
DCAP	Intel SGX-based DCAP (data center attestation primitives) for the platform certificate after registration.	<a href="https://github.com/intel/SGXDataCenterAttestationPrimitives">https://github.com/intel/SGXDataCenterAttestationPrimitives</a>
QGS	QGS provides the functionality of Intel TDX quote generation within an Intel SGX-based quote enclave. It is part of the DCAP running on the IaaS host or legacy VM.	<a href="https://github.com/intel/SGXDataCenterAttestationPrimitives">https://github.com/intel/SGXDataCenterAttestationPrimitives</a>
Intel TDX Guest Kernel	The guest kernel with Intel TDX patches being upstreamed.	<a href="https://github.com/intel/tdx/tree/guest-upstream">https://github.com/intel/tdx/tree/guest-upstream</a>
Grub2	The bootloader grub2 with Intel TDX patches already upstreamed.	<a href="https://github.com/intel/grub-tdx/tree/2.06-upstream-v4">https://github.com/intel/grub-tdx/tree/2.06-upstream-v4</a>
Shim	The bootloader shim with Intel TDX patches already upstreamed.	<a href="https://github.com/intel/shim-tdx">https://github.com/intel/shim-tdx</a>
Intel TDX Attestation Agent	A sample Intel TDX attestation agent to call TDVMCALL.getQuote(). It is part of DCAP.	<a href="https://github.com/intel/SGXDataCenterAttestationPrimitives">https://github.com/intel/SGXDataCenterAttestationPrimitives</a>
PyTdxMeasure	A Python measurement library that dumps RTMR, the CCEL ACPI table, and verifies the	<a href="https://github.com/intel/tdx-tools">https://github.com/intel/tdx-tools</a>

	RTMR via replaying the TD event log.	
--	--------------------------------------	--

*NOTE: Some of the components have completed patch upstreaming such as Grub, Shim, and TDVF, while others are still in progress.*

## 2.4 Building Stacks

For an end-to-end stack setup and validation, tdx-tools provides downstream patches and a build tool to construct the whole stack in a few simple steps.

The supported distros' versions are as follows for both host and guest packages:

- RHEL 8.x (Latest Version)
- Ubuntu 22.04

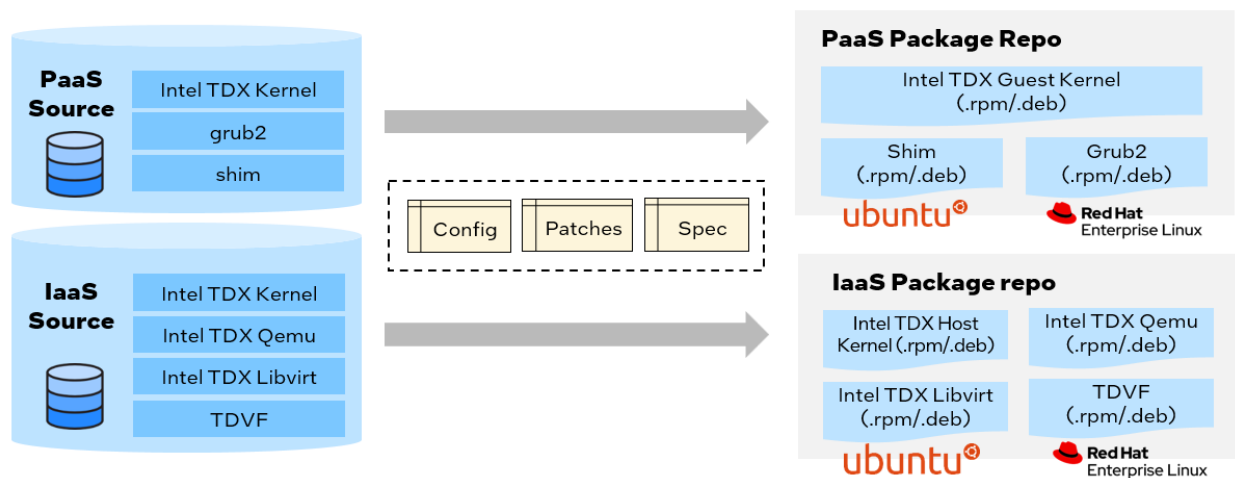

Figure 8: End-to-End Host and Guest Stack for Linux and Intel TDX

The end-to-end stack building includes two steps on any Linux development machine:

- Step 1: Build packages
- Step 2: Create guest image

### 2.4.1 Build Packages

A `build.sh` script is provided by tdx-tools to download the upstream source, apply Intel TDX patches from the directory `<build>/common`, and do package building.

Note: When obtaining *tdx-tools*, please make sure to use the correct tag which matches the release version.

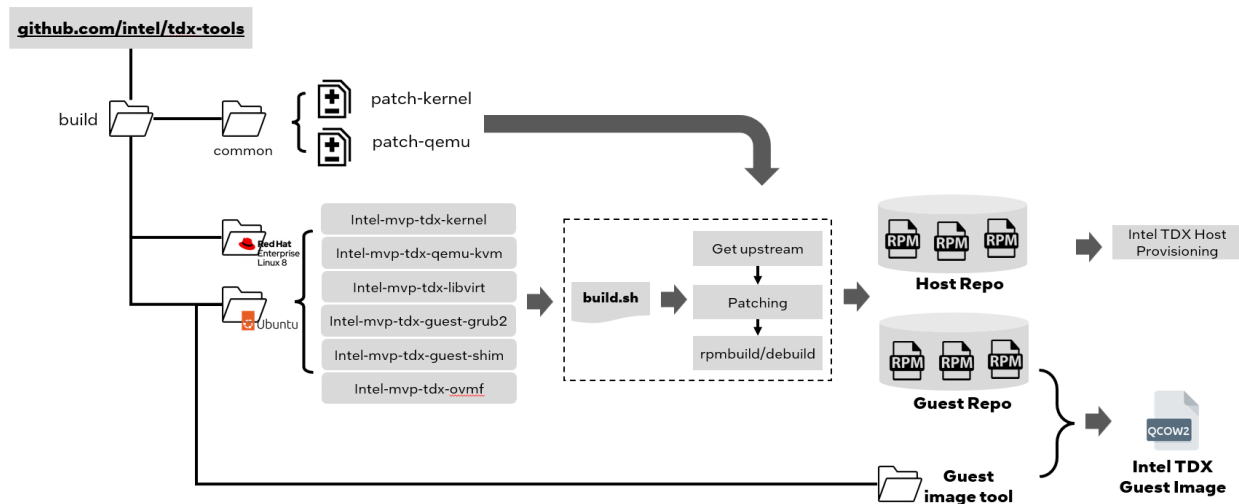

Figure 9: Build process for Intel TDX packages

The kernel config is provided in the kernel package directory with Intel TDX configurations. For example, RHEL-8 will use the path `build/rhel-8/intel-mvp-tdx-kernel/tdx-kernel.spec`. All kernel configurations have been optimized for TDX performance.

Below is an example using Ubuntu 22.04 to build the entire repo with all the packages.

**NOTE:** The building process may take more than 1 hour or longer depending on the resource of building server.

```

$ # Follow https://docs.docker.com/engine/install/ to setup Docker.
$ # Add current user into docker group
$ sudo usermod -G docker -a $USER
$ # Restart docker service
$ sudo systemctl restart docker

$ # Make sure you get the correct tag. Here is an example of getting 2023ww33 tag
$ git clone git@github.com:intel/tdx-tools.git --branch 2023ww33
$ cd build/ubuntu-22.04/
$
$ # Build the all packages via build-repo.sh, and running it within pkg-builder
$ # container to avoid any issues of build environment
$ ./pkg-builder build-repo.sh

```

Below is an example of how to build individual packages on Ubuntu 22.04.

```
$ # If want to build individual package like intel-mvp-tdx-kernel
$ ./pkg-builder intel-mvp-tdx-kernel/build.sh
```

After the packages have been built successfully, two repositories are generated.

1. `build/ubuntu-22.04/host_repo`: includes the Intel TDX host kernel, Intel TDX QEMU, Intel TDX Libvirt, and TDVF.
2. `build/ubuntu-22.04/guest_repo`: includes the Intel TDX guest kernel, grub2, and shim.

## 2.4.2 Create Guest Image

The Intel TDX virtual machine requires guest images to be booted with an Intel TDX guest kernel, Intel TDX grub2 and shim packages for both grub boot and secure boot.

The image creation process is a little different for the different distros:

- Ubuntu 22.04 guest image

Ubuntu provides EFI enabled guest/cloud images at <https://cloud-images.ubuntu.com/>. Use `<tdx-tools>/build/ubuntu-22.04/guest-image/create-ubuntu-image.sh` as follows:

```
$ # Prerequisite: build the Ubuntu packages via build-repo.sh
$ # Install dependencies
$ sudo apt install libguestfs-tools

$ cd build/ubuntu-22.04/guest-image
$
$ # Install guest repo packages into guest image. Please provide guest repo
$ # directory which is generated in the Build Packages chapter
$ ./create-ubuntu-image.sh -r $GUEST_REPO
```

The `$GUEST_REPO` is the path to guest repo, which has the following file hierarchy.

```
guest_repo/
|- all/
|- amd64/
```

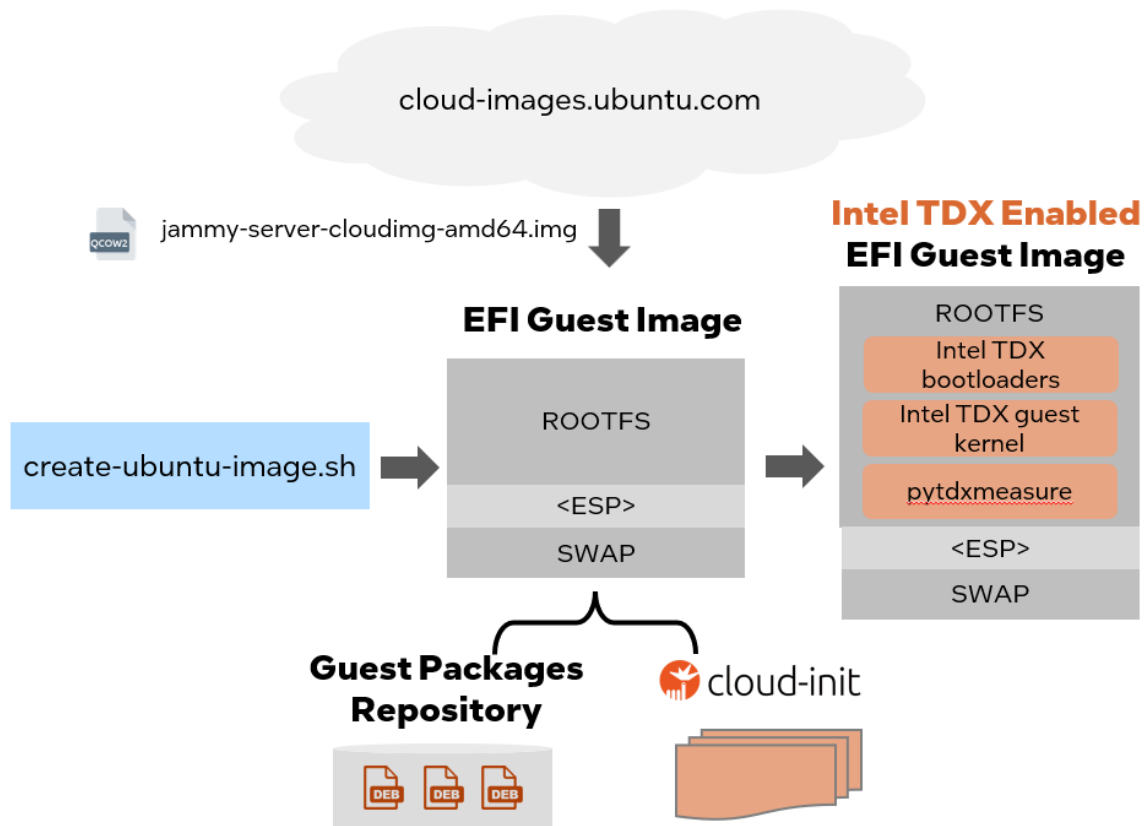

Figure 10: Create Intel TDX Ubuntu Guest Image

NOTE: The guest image can be further customized at [tdx-tools>/build/ubuntu22.04/guest-image](https://github.com/intel/tdx-tools/blob/master/build/ubuntu22.04/guest-image):

```
Usage: create-ubuntu-image.sh [OPTION]...
Required
-r <guest repo>          Specify the directory including guest packages,
                        generated by build-repo.sh or remote repo
Test suite
-t                       Install test suite
Optional
-v <kernel version>     Specify the version of the guest kernel, like 5.19.17-
                        mvp29v4+4-generic of
                        linux-image-unsigned-5.19.17-mvp29v4+4-generic. If the
                        guest repo is remote,
                        the option is necessary.
-a                       Auth file that will be placed in /etc/apt/auth.conf.d
-h                       Show this help
-f                       Force to recreate the output image
-n                       Guest host name, default is "tdx-guest"
-u                       Guest user name, default is "tdx"
-p                       Guest password, default is "123456"
-s                       Specify the size of guest image
-o <output file>       Specify the output file, default is tdx-guest-ubuntu-
                        22.04.qcow2.
```

```

Please make sure the suffix is qcow2. Due to permission
consideration,
the output file will be put into /tmp/<output file>.
Debug Mode
-b          - enable root login
  
```

- RHEL 8.x guest image  
The default distro cloud image does not support an EFI schema. The tdx-tools repository provides [<tdx-tools>/build/rhel-8/guest-image/create-efi-img.sh](#) to create a RHEL EFI guest image via the kickstart<sup>1</sup> tool.

Use [tdx-guest-stack.sh](#) to install the Intel TDX guest packages into the image using the following workflow.

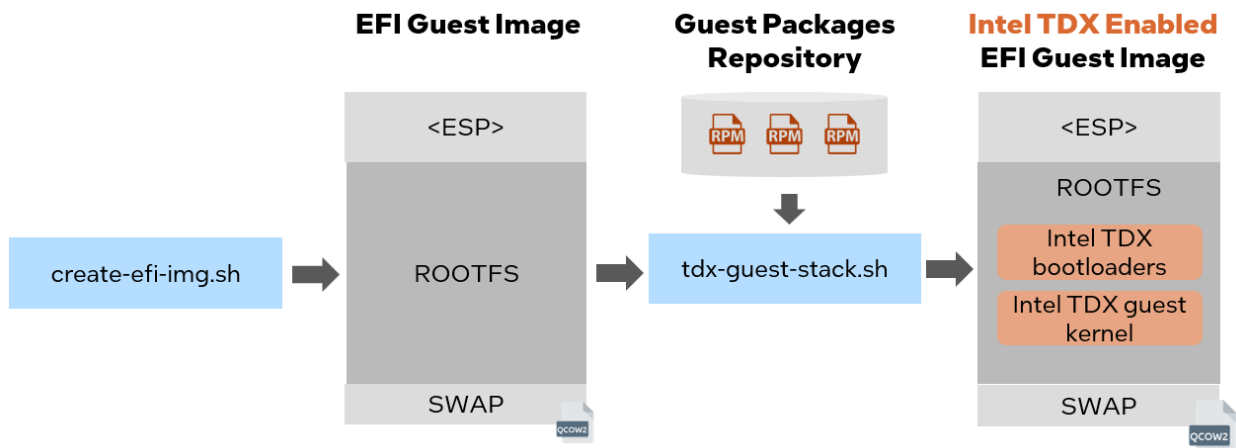

Figure 11: Create Intel TDX RHEL guest image

## 2.5 Install IaaS Host

Perform the following steps to deploy the packages on IaaS host.

*NOTE: Please disable Intel TDX in the BIOS to install the Intel TDX packages. Before installing the Intel TDX host kernel, the distro default kernel may unintentionally cleanup MTRR (memory type range register) for the Intel TDX memory range. This will cause an MCHECK error. Once the Intel TDX packages*

<sup>1</sup> <https://linuxhint.com/beginners-kickstart/>

have been installed, set the Intel TDX kernel as the default in grub, reboot, and enable Intel TDX in the BIOS.

## 2.5.1 Install Packages by Manual

### For Ubuntu 22.04 host

- Install all Debian packages.

```
$ # Build the DEB packages via the above steps, the DEB packages will be generated
$ # to <tdx-tools>/build/ubuntu-22.04/host_repo/
$ cd host_repo
$ sudo apt -y --allow-downgrades install ./*.deb
```

- Add `numa_balancing=disable` into grub menu.

```
$ vi /etc/default/grub

# Add "numa_balancing=disable" in GRUB_CMDLINE_LINUX_DEFAULT
GRUB_CMDLINE_LINUX_DEFAULT=". . . numa_balancing=disable"

$ sudo update-grub
```

- Set TDX kernel as default kernel.

```
$ grep -A100 submenu /boot/grub/grub.cfg | grep menuentry | grep <TDX kernel
version>

$ # Use the string in above output, such as "gnulinux-6.2.0-mvp4v1+2-
$ # generic-advanced-34db9317-bf73-44c3-8425-2fa83446e8d5" in
$ # /etc/default/grub file as value of "GRUB_DEFAULT"

$ vi /etc/default/grub
# Below value is just an exmaple. Please do Not use it directly. Please use the
string from output of last command.
GRUB_DEFAULT="gnulinux-6.2.0-mvp4v1+2-generic-advanced-34db9317-bf73-44c3-8425-
2fa83446e8d5"

$ sudo update-grub
```

*NOTE: Change the default string according to your TDX kernel version.*

### For RHEL 8.x host

- Move the generated host repo to a directory that will be used in the repo file.

```
$ sudo mkdir -p /srv/
$
$ # Build the RPM packages via above steps, the RPM package will be generated
$ # in <tdx-tools>/build/rhel-8/host_repo/
$ sudo mv build/rhel-8/host_repo/ /srv/tdx-host
```

- Set up the host repository. Generate the file `/etc/yum.repos.d/tdx-host-local.repo` and add the following content.

```
$ cat /etc/yum.repos.d/tdx-host-local.repo
[tdx-host-local]
name=tdx-host-local
baseurl=file:///srv/tdx-host
enabled=1
gpgcheck=0
module_hotfixes=true
```

- Add the EPEL repo. It provides the packages of `capstone` and `libcapstone` required by Intel TDX QEMU.

```
$ sudo dnf install https://dl.fedoraproject.org/pub/epel/epel-release-latest-8.noarch.rpm
```

- Install the host packages.

```
$ sudo dnf install intel-mvp-tdx-kernel intel-mvp-tdx-qemu-kvm intel-mvp-ovmf
intel-mvp-tdx-libvirt
```

- If you get an error about `qemu-kvm` conflicts, remove the existing `qemu-kvm` package with the following command, and then re-run the command above to install host packages.

```
$ sudo dnf remove qemu-kvm
```

- Add `numa_balancing=disable` into grub menu.

```
$ vi /etc/default/grub

# Add "numa_balancing=disable" in GRUB_CMDLINE_LINUX
GRUB_CMDLINE_LINUX="... numa_balancing=disable"

$ sudo grub2-mkconfig -o /boot/efi/EFI/redhat/grub.cfg
```

- Set TDX kernel as default kernel.

```
$ ls /boot/vmlinuz* | grep <kernel-version>

$ # Use output of above command, such as
$ # "/boot/vmlinuz-6.2.0-tdx.v1.5.mvp7.el8.x86_64" in the
$ # below command

$ sudo grubby --set-default=/boot/vmlinuz-<kernel version>
```

## 2.5.2 Deploy via Ansible

Use the ansible based “TDX Deployment Tool” to deploy the host stack to multiple server nodes or guest stack to multiple TD VMs.



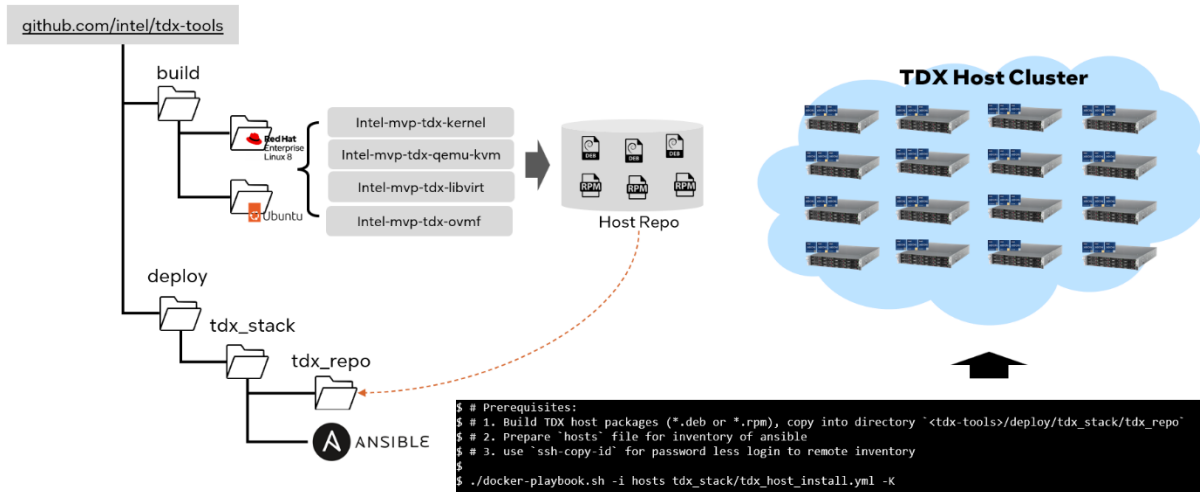

Figure 12: Deploy TDX host stack via Ansible

NOTE: Current Ansible script only support deployment on Ubuntu22.04.

Before using the script there are a couple pre-requisites.

1. Build the host \*.deb repositories. Refer to section 2.4.1 Build Packages. The final built files will be at <tdx-tools>/build/ubuntu-22.04/host\_repo.
2. Copy all \*.deb packages to <tdx-tools>/deploy/tdx\_stack/tdx\_repo/

```
$ cp build/ubuntu-22.04/host_repo/*.deb deploy/tdx_stack/tdx_repo/
```

3. Prepare ansible inventory host file and enable password-less login on all managed nodes, please refer [tutorial](#).

```
$ # The content of an example inventory file
$ cat deploy/tdx_stack/hosts
tdx@10.0.0.2
tdx@10.0.0.3
tdx@10.0.0.4

$ # Enable the SSH password less login
$
$ ssh-copy-id tdx@10.0.0.2
...
$ ssh-copy-id tdx@10.0.0.3
...
$ ssh-copy-id tdx@10.0.0.4
```

4. Setup ansible docker to create the build image

```
$ ./docker-playbook.sh rebuild
```

5. Run playbook in docker for auto deployment process on all managed nodes

```
$ ./docker-playbook.sh -i hosts tdx_stack/tdx_host_install.yml -K
```

### 2.5.3 Reboot with the Intel TDX kernel

After installing the Intel TDX kernel and host packages successfully, reboot the system into the BIOS menu and enable Intel TDX. Refer to Section 2.2 on the BIOS settings. To verify that Intel TDX is enabled by using the script [check-tdx-host.sh](#) after the system is booted. Alternatively, the below steps can also be used to determine that Intel TDX has been successfully enabled.

- Check whether TDX Module is initialized. The expected output is “TDX module initialized”.

```
$ sudo dmesg | grep -i tdx
...
tdx: TDX module initialized.
```

- Check Intel TME enable status; expect a return code of 1.

```
$ sudo rdmsr -f 1:1 0x982
1
```

- Check Intel TME max keys.

```
$ sudo rdmsr -f 50:36 0x981
```

- Check the Intel SGX and MCHECK status, expecting a code of 0.

```
$ sudo rdmsr 0xa0
0
```

- Check the Intel TDX Status, expecting a code of 1.

```
$ sudo rdmsr -f 11:11 0x1401
1
```

*NOTE: All the above checking steps should be successful with expected result returned before moving forward to the next steps.*

- Check the number of Intel TDX keys.

```
$ sudo rdmsr -f 63:32 0x87
1
```

- Check the information for the Intel TDX module.

```
$ cat /sys/firmware/tdx/tdx_module/*
```

# 3 Manage the TD guest

Like a normal virtual machine, a TD guest can be launched by QEMU via command line or orchestrated by Libvirt via XML templates. This chapter introduces how to manage the lifecycle of a TD guest for diverse boots such as secure boot, direct boot, and grub boot.

*NOTE: Please make sure to use the correct tag of tdx-tools which matches the release version.*

## 3.1 Overview

You can boot a TD guest either by using the QEMU command line or by using a Libvirt XML template and virsh commands. Libvirt translates the XML template to QEMU commands and calls qemu-kvm to complete the VM boot. Similarly, you can call qemu-kvm directly with parameters to boot a VM.

The following diagram illustrates the TD guest boot type and boot process.

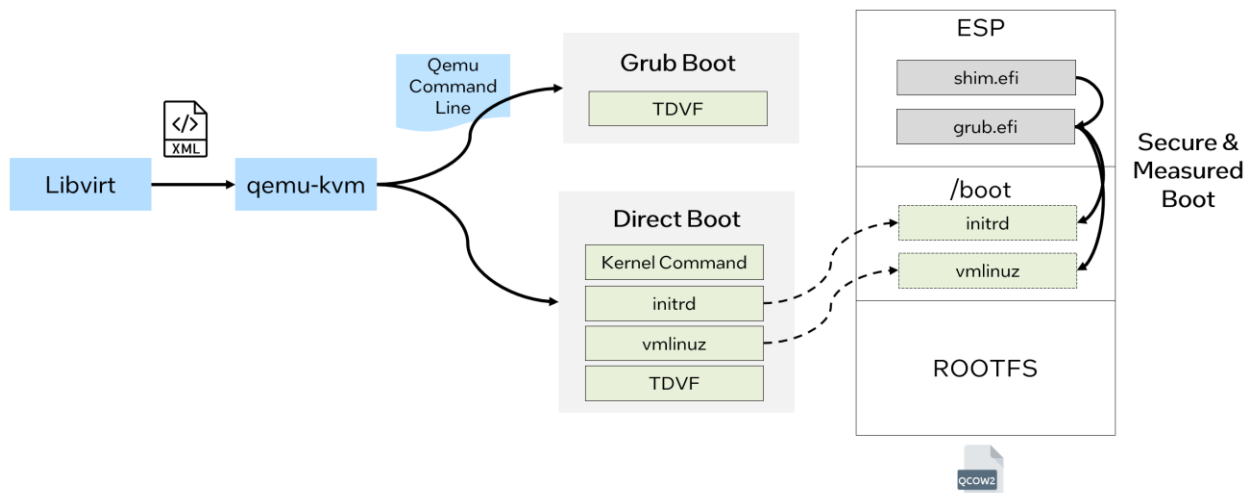

Figure 13: TD Guest Boot Process

The following table explains different boot types:

Table 3: Boot Types for TD Guest

Boot Type	Description	Difference from a non-confidential VM
<b>Direct Boot</b>	Boot the guest by explicitly specifying kernel binary via QEMU launching parameter "-kernel", specifying the initrd binary via QEMU launching parameter "-initrd", specifying the kernel command via QEMU launching parameter "-append". Bootloaders, such as shim/grub are not involved in direct boot.	No differences on QEMU launch parameters for confidential VM, but requires TDVF/OVMF to do measured boot and record the measurement into RTMR(Runtime Measurement Register) register
<b>Grub Boot</b>	Boot the guest without "-kernel" and "-append" in QEMU launching params. The OVMF/TDVF searches for and starts the bootloader from ESP	No differences on QEMU launch parameters for confidential VM, but requires Intel TDX Grub2 to do measured boot and record the measurement into RTMR register
<b>Measured Boot</b>	It is the process of measuring and storing securely (i.e. using a TPM) the next stage object in the boot process by the UEFI BIOS, bootloader, kernel, etc.	The secure register is a PCR register in a trusted computing group (TCG)-defined trusted platform module (TPM), while is RTMR in Intel TDX module
<b>Secure Boot</b>	Secure boot is a security standard developed by members of the PC industry to help make sure that a device boot using only software that is trusted by the original equipment manufacturer (OEM). The Secure boot certificate should be protected by measured boot.	The secure boot certificate can be enrolled in runtime of guest VM for non-confidential VM, while the secure boot must be enrolled in TDVF offline for the consistent measurement on MRTD (measurement of trust domain)

The detail boot flow for different TD boot methods can be found in Figure 14:  
Detailed boot flow for different TD boot

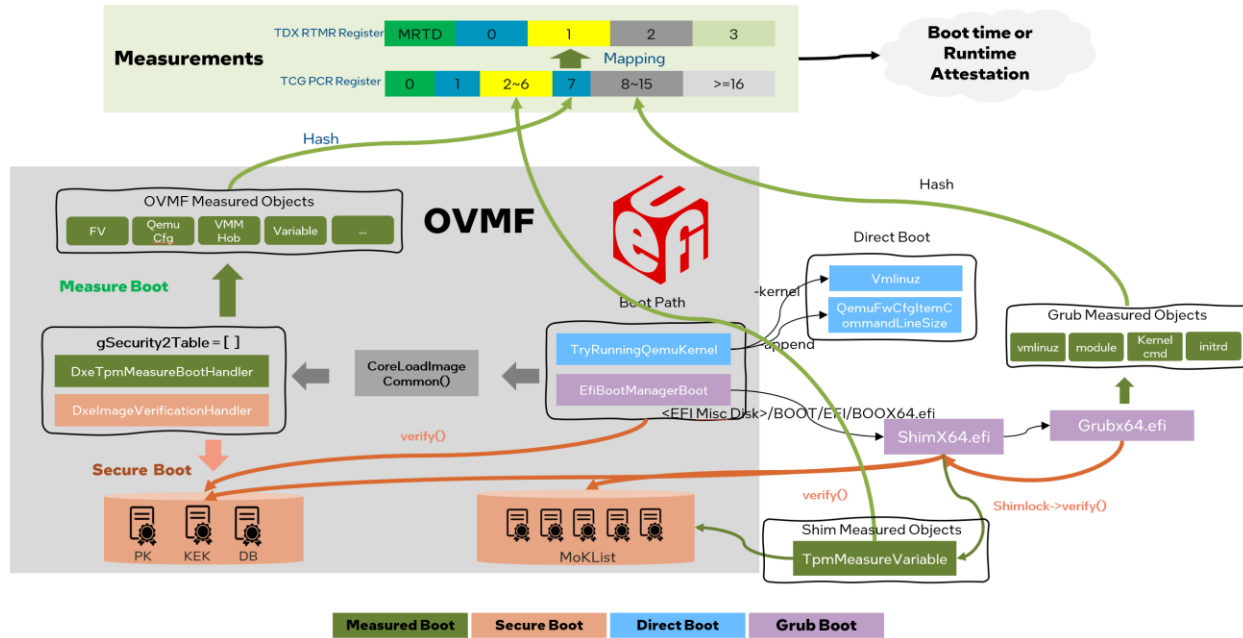

Figure 14: Detailed boot flow for different TD boot

In Figure 14: Detailed boot flow for different TD boot:

### Measured Boot

1. In OVMF, the image handler `DxeTpmMeasureBootHandler` will be triggered when loading EFI image via `CoreLoadImageCommon()`.
2. In OVMF, `DxeTpmMeasureBootHandler` will measure the objects like FV, QEMU CFG, VMM Hob, Variable into TCG PCR Register. In TD guest, the measurement will also be extended to RTMR register if vTPM does not exist.
3. In boot loader ShimX64.efi, `TpmMeasureVariable()` will measure the secure boot's certificates into TCG PCR or TDX RTMR register.
4. Boot loader GrubX64.efi measures kernel binary and cmdline, initrd binary and grub's module into TCG PCR or TDX RTMR register.

The mapping between TCG PCR register and RTMR is

- PCR #1, #7 ⇔ RTMR #0
- PCR #2~#6 ⇔ RTMR #1
- PCR #8~#15 ⇔ RTMR #2

### Secure Boot

1. In OVMF, the image handler `DxeImageVerificationHandler` will be triggered when loading EFI image via `CoreLoadImageCommon()`

2. In OVMF, `DxeImageVerificationHandler` will use UEFI secure boot's DB key to verify the certificate from each of load EFI image.
3. `ShimX64.efi` and `GrubX64.efi` will use UEFI secure boot's DB key or Linux secure boot's MoK (Machine Owner Key) to verify the certificate of kernel, kernel module etc.
4. All certificates, including UEFI secure boot and Linux secure boot, are measured into TDX RTMR register.

## Direct Boot

1. In direct boot path, the kernel binary is started and measured by `TryRunningQEMUKernel()`.
2. In direct boot path, the kernel command and `initrd` are measured by the EFI stub of Linux kernel.

Refer to the [measure log for direct boot](#) for a sample of what the output should look like.

## Grub Boot

1. In grub boot, `ShimX64.efi` will help bring the UEFI secure boot to Linux secure boot. Normally UEFI secure boot will use MSFT UEFI certificates<sup>3</sup>. But here it needs a new key to sign customized kernel/grub/shim, please refer 3.3 Secure Boot
2. In grub boot, `GrubX64.efi` will measure kernel binary/command and `initrd` binary.

Refer the [measure log for grub boot](#).

---

<sup>3</sup> <https://learn.microsoft.com/en-us/windows-hardware/manufacture/desktop/windows-secure-boot-key-creation-and-management-guidance?view=windows-11>

## 3.2 Boot TD Guest

### 3.2.1 Launch via QEMU

Since the QEMU parameter list is quite long and complicated, tdx-tools provides the start-qemu.sh script to handle some parameters by default. It supports both direct boot and grub boot of TD guest. It also provides a few interactive parameters to meet customization requirements.

*Note: The parameters in "start-qemu.sh" may vary along with different Intel TDX kernel and Intel TDX QEMU versions. Please make sure to use the correct tag of tdx-tools which matches the release.*

The start-qemu.sh script offers several parameters to boot TD guests on demand. The parameters are listed in Table 4: start-qemu.sh parameters:

Table 4: start-qemu.sh parameters

Parameter	Description
<code>-i &lt;guest image file&gt;</code>	Guest image file name and location
<code>-k &lt;kernel file&gt;</code>	Kernel binary name and location
<code>-t [legacy   efi   td]</code>	VM type supported; default is "td"
<code>-b [direct   grub]</code>	Boot type, default value is "direct" which requires kernel binary specified via "-k"
<code>-p &lt;Monitor port&gt;</code>	Monitor port via telnet. Refer to the usage of <a href="#">QEMU Monitor</a>
<code>-f &lt;SSH Forward port&gt;</code>	Host port used for guest VM SSH forwarding. Refer to <a href="#">QEMU SSH port forwarding</a>
<code>-o &lt;OVMF file&gt;</code>	BIOS firmware device file. OVMF/TDVF is used for "td" and "efi" VM type. "efi" is used for non-confidential VM, while "td" is used for TD VM guest
<code>-m &lt;11:22:33:44:55:66&gt;</code>	MAC address of VM. If MAC address changes for a TD guest, RTMR value will change and Intel TDX measurement will fail
<code>-q [tdvmcall   vsock]</code>	TD quote generation supports using tdvmcall or vsock. Choose the corresponding value to boot TD guest.
<code>-c &lt;number&gt;</code>	Number of vCPU. Default value is 1.
<code>-r &lt;root partition&gt;</code>	Root partition for direct boot, default is /dev/vda3
<code>-e &lt;extra kernel command&gt;</code>	Extra kernel command needed in VM boot
<code>-v</code>	Flag to enable vsock
<code>-d</code>	Flag to enable "debug=on" for GDB guest. Refer to chapter 6 Develop & Debug

<b>-s</b>	Flag to use serial console instead of hypervisor virtual console (HVC).
<b>-h</b>	Show usage help

- Direct boot TD guest via QEMU command

This is an example of direct boot using start-qemu.sh. You need to provide the guest image and kernel image as shown. Direct boot is used by default, so it's not required to use "-b direct".

```
$ ./start-qemu.sh -i <guest image> -k <kernel binary>
```

- Grub boot TD guest via QEMU command

This is an example of grub boot using start-qemu.sh. You need to provide the guest image and specify to use grub boot via "-b grub".

```
$ ./start-qemu.sh -i <guest image> -b grub
```

- Direct boot non-confidential guest via QEMU command

This is an example of how to direct boot a non-TD guest. Provide the guest image and kernel image as shown. It requires using "-t efi" to boot non-confidential guest via OVMF/TDVF or "-t legacy" to boot non-confidential guest via legacy [SeaBIOS](#).

```
$ ./start-qemu.sh -i <guest image> -k <kernel image> -t efi
$ ./start-qemu.sh -i <guest image> -k <kernel image> -t legacy
```



## 3.2.2 Launch via Libvirt

Libvirt is a popular orchestrator to manage the VM guest via the virsh command. Tdx-tools provides both direct boot and grub boot XML templates for TD guest at `tdx-tools/doc/`.

Template	Description
<code>tdx_libvirt_direct.xml.template</code>	TD guest direct boot
<code>tdx_libvirt_grub.xml.template</code>	TD guest grub boot

*NOTE: The templates may vary with a different kernel version or QEMU version. Please make sure to use the correct tag of tdx-tools which matches the release version.*

To create the final VM's XML from the template, update the XML template to refer to the guest image, kernel image, and OVMF binary:

- Update OVMF binary

```
<loader>/path/to/OVMF.fd</loader>
```

- Update guest image

```
<source file="/path/to/guest-image.qcow2"/>
```

- Update kernel image (This is not needed when using grub boot template)

```
<kernel>/path/to/vmlinuz-jammy</kernel>
```

Unlike QEMU, Libvirt uses the concept of a domain to manage the VM lifecycle across reboot cycle. Libvirt distinguishes between two different types of domains: transient and persistent<sup>4</sup>.

- Transient domains only exist until the domain is shut down or when the host server is restarted.
- Persistent domains last indefinitely.

This example uses a Transient domain to start a TD guest:

```
$ virsh create tdx_libvirt_direct.xml
```

Check whether a TD guest is running with the following command. It's expected to see a TD guest running.

<sup>4</sup> [https://wiki.libvirt.org/VM\\_lifecycle.html](https://wiki.libvirt.org/VM_lifecycle.html)

```
$ virsh list
Id   Name                               State
-----
2    td-guest                            running
```

Enter the TD guest console with the following command.

```
$ virsh console <TD guest name>
```

### 3.3 Secure Boot

Secure boot for a TD guest is almost the same as a traditional non-confidential VM. The major difference is the OVMF.fd/TDVF.fd needs to be measured into MRTD statically. Since the EFI variable is read-only in runtime with TDX guest VM, it does not permit enrolling the secure boot key into the EFI variable FV (firmware volume) via a tool such as [EnrollDefaultKey](#) at runtime. Instead, a new tool [ovmfkeyenroll](#) from tdx-tools is developed to help enroll the secure boot certificate offline before measurement.

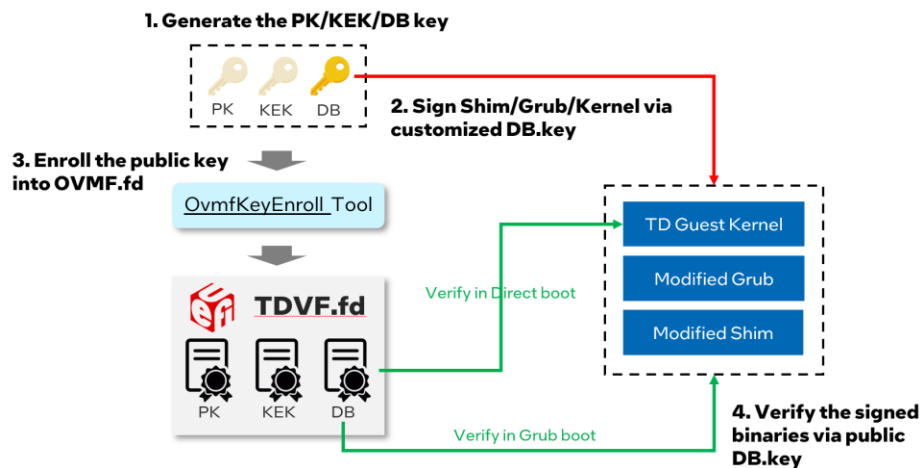

Figure 15: Enable Secure Boot

The steps of enrolling the secure boot key are as follows:

- Step 1: Generate customized secure boot keys and certificates, instead of using a Microsoft certificate.

```
#!/bin/bash
NAME="Test"
openssl req -new -x509 -newkey rsa:2048 -subj "/CN=$NAME PK/" -keyout PK.key \
-out PK.crt -days 3650 -nodes -sha256
openssl req -new -x509 -newkey rsa:2048 -subj "/CN=$NAME KEK/" -keyout KEK.key \
-out KEK.crt -days 3650 -nodes -sha256
```

```
openssl req -new -x509 -newkey rsa:2048 -subj "/CN=$NAME DB/" -keyout DB.key \
-out DB.crt -days 3650 -nodes -sha256
openssl x509 -in PK.crt -out PK.cer -outform DER
openssl x509 -in KEK.crt -out KEK.cer -outform DER
openssl x509 -in DB.crt -out DB.cer -outform DER
GUID=$(python3 -c 'import uuid; print(str(uuid.uuid1()))')
echo $GUID > myGUID.txt
chmod 0600 *.key
```

Refer to the following to learn more about the different types of digital certificates.

- [Managing EFI Boot Loaders for Linux: Controlling Secure Boot](#)
- [UEFI Specification](#)
- Step 2: Build and install ovmfkeyenroll tool, Refer to [source](#)
- Step 3: Enroll key into OVMF.fd (aka TDVF.fd)

```
$ ovmfkeyenroll -fd <absolute-path-to-OVMF.fd> \
-pk <pk-key-guid> <absolute-path-to>/PK.cer \
-kek <kek-guid> <absolute-path-to>/KEK.cer \
-db <db-key-guid> <absolute-path-to>/DB.cer
```

*NOTE: Replace GUID with the content of myGUID.txt generated above.*

- Step 4: Install signing tool
  - Option 1: Build from source: [sbsigntools](#)
  - Option 2: Use RPM or DEB packages built by a third-party.

```
$ wget https://download-
ib01.fedoraproject.org/pub/fedora/linux/releases/33/Everything/
x86_64/os/Packages/s/sbsigntools-0.9.4-2.fc33.x86_64.rpm
$ sudo rpm -ihvf sbsigntools-0.9.4-2.fc33.x86_64.rpm
```

- Step 5: Extract the following components from the guest's packages
  - shimx64.efi
  - mmx64.efi
  - grubx64.efi
  - fbx64.efi
  - guest kernel binary file like vmlinuz
- Step 6: Sign Shim/Grub/Kernel with customized secure boot key

```
$ sbsign --key <path-to>/DB.key --cert <path-to>/DB.crt --output shimx64-
signed.efi shimx64.efi
$ sbsign --key <path-to>/DB.key --cert <path-to>/DB.crt --output mmx64-signed.efi
mmx64.efi
$ sbsign --key <path-to>/DB.key --cert <path-to>/DB.crt --output grubx64-
signed.efi grubx64.efi
$ sbsign --key <path-to>/DB.key --cert <path-to>/DB.crt --output fbx64-signed.efi
fbx64.efi
$ sbsign --key <path-to>/DB.key --cert <path-to>/DB.crt --output vmlinuz-signed
vmlinuz-<guest-kernel-version>
```

*NOTE: if the DB.key or DB.crt file to be signed is not in the same directory then a relative address needs to be used.*

The following files are created:

- shimx64-signed.efi
  - mmx64-signed.efi
  - grubx64-signed.efi
  - fbx64-signed.efi
  - vmlinuz-signed
- Step 7: Customize guest QCOW2 Image
    - Create the directories for mounting ESP and rootfs partitions:

```
$ mkdir -p workspace/efi
$ mkdir -p workspace/rootfs
```

- Connect the QCOW2 image to `/dev/nbdx`:

```
$ sudo modprobe nbd max_part=8
$ sudo qemu-nbd --connect=/dev/nbd0 /path/of/td-guest.qcow2
```

- Mount ESP and rootfs

For RHEL 8.x:

```
$ sudo mount /dev/nbd0p2 workspace/efi
$ sudo mount /dev/nbd0p3 workspace/rootfs
```

For Ubuntu 22.04:

```
$ sudo mount /dev/nbd0p15 workspace/efi
$ sudo mount /dev/nbd0p1 workspace/rootfs
```

- Replace the files

For RHEL 8.x:

```
$ sudo su
$ cp /path/to/shimx64-signed.efi workspace/efi/EFI/BOOT/BOOTX64.EFI
$ cp /path/to/shimx64-signed.efi workspace/efi/EFI/redhat/shimx64.efi
$ cp /path/to/mbx64-signed.efi workspace/efi/EFI/BOOT/mbx64.efi
$ cp /path/to/mmx64-signed.efi workspace/efi/EFI/BOOT/mmx64.efi
$ cp /path/to/mmx64-signed.efi workspace/efi/EFI/redhat/mmx64.efi
$ cp /path/to/grubx64-signed.efi workspace/efi/EFI/redhat/grubx64.efi

$ # please pay attention to replace the correct version of the kernel
$ cp /path/to/vmlinuz-signed workspace/rootfs/boot/vmlinuz-<kernel-version>
```

For Ubuntu 22.04:

```
$ sudo su
$ cp /path/to/shimx64-signed.efi workspace/efi/EFI/BOOT/BOOTX64.EFI
$ cp /path/to/shimx64-signed.efi workspace/efi/EFI/ubuntu/shimx64.efi
$ cp /path/to/mbx64-signed.efi workspace/efi/EFI/BOOT/mbx64.efi
$ cp /path/to/mmx64-signed.efi workspace/efi/EFI/BOOT/mmx64.efi
```

```
$ cp /path/to/mmx64-signed.efi workspace/efi/EFI/ubuntu/mmx64.efi
$ cp /path/to/grubx64-signed.efi workspace/efi/EFI/ubuntu/grubx64.efi
$
$ # please pay attention to replace the correct version of the kernel
$ cp /path/to/vmlinuz-signed workspace/rootfs/boot/vmlinuz-<kernel-version>
```

- Step 8: Unmount the ESP and rootfs partitions:

For RHEL 8.x:

```
$ sudo mount /dev/nbd0p2 workspace/efi
$ sudo mount /dev/nbd0p3 workspace/rootfs
```

For Ubuntu 22.04:

```
$ sudo mount /dev/nbd0p15 workspace/efi
$ sudo mount /dev/nbd0p1 workspace/rootfs
```

- Step 9: Disconnect the QCOW2 image

```
$ sudo qemu-nbd --disconnect /dev/nbd0
```

Use the modified OVMF.sb.fd and tdx-guest.sb.qcow2 to start a TDVM and verify whether the secure boot is enabled via the dmesg log:

```
$ dmesg | grep -i "Secure Boot"
```

It is expected to show "Secure Boot Enabled"

## 3.4 Use VirtIO Device

Within the Intel TDX guest, the drivers are the largest threat attack surface by far. They access the host-controlled PCI config space to perform MMIO and port IO. Refer to Figure 16: TDX Guest Attack Surface or detail threat analysis at [2].

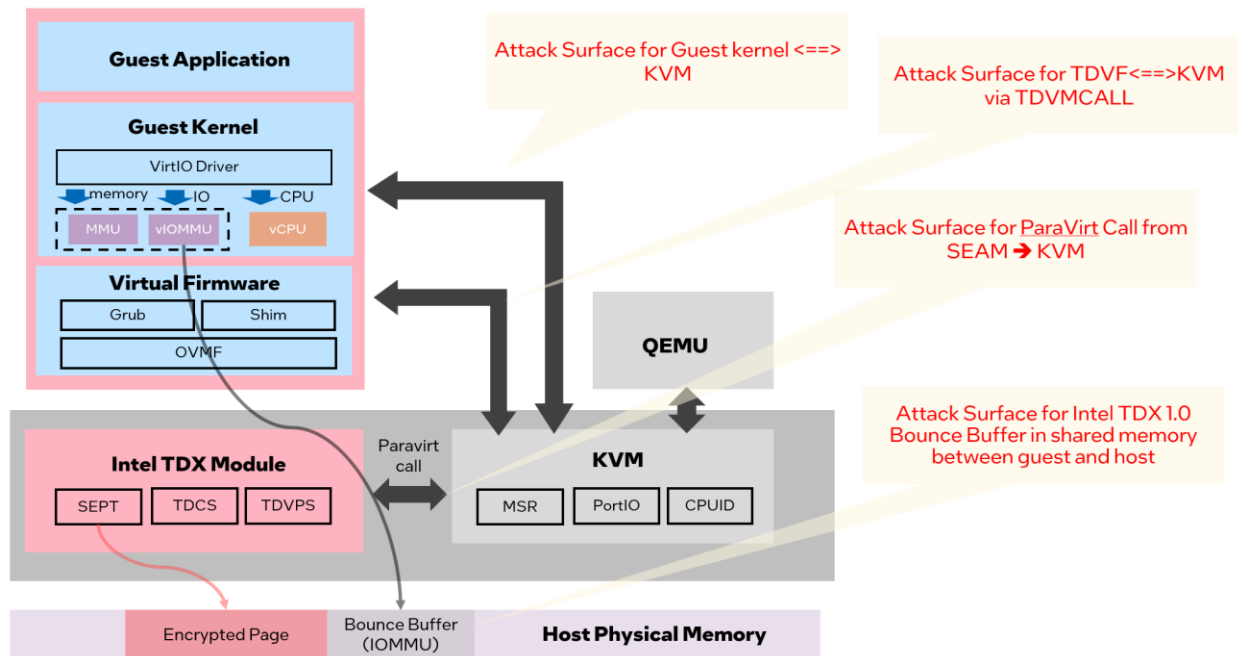

Figure 16: TDX Guest Attack Surface

To mitigate this risk there is a curated list of drivers that are enabled in the runtime for the TD guest kernel. By default, all PCI and ACPI bus drivers are blocked unless they are in the allow-list. The current default allow-list for the PCI bus is limited to the following VirtIO drivers:

- virtio\_net
- virtio\_console
- virtio\_blk
- 9pnet\_virtio
- virtio\_vsock

Since most of the ACPI tables are not needed for an Intel TDX guest, the implemented ACPI table allow-list limits them to a small, predefined list with a possibility to pass additional tables via a command line option. The current allow-list is limited to the following tables:

- XSDT
- FACP
- DSDT
- FACS
- APIC
- SVKL

- CCEL

### 3.5 Full Disk Encryption

FDE (Full disk encryption) is a security method for protecting sensitive data by encrypting all data on a disk partition. In non-confidential VM, FDE is using LUKS (Linux Unified Key Setup) with a user input disk encryption key. In confidential environments like Intel TDX, to achieve zero trust, the encryption key should be retrieved from the replying party via remote attestation.

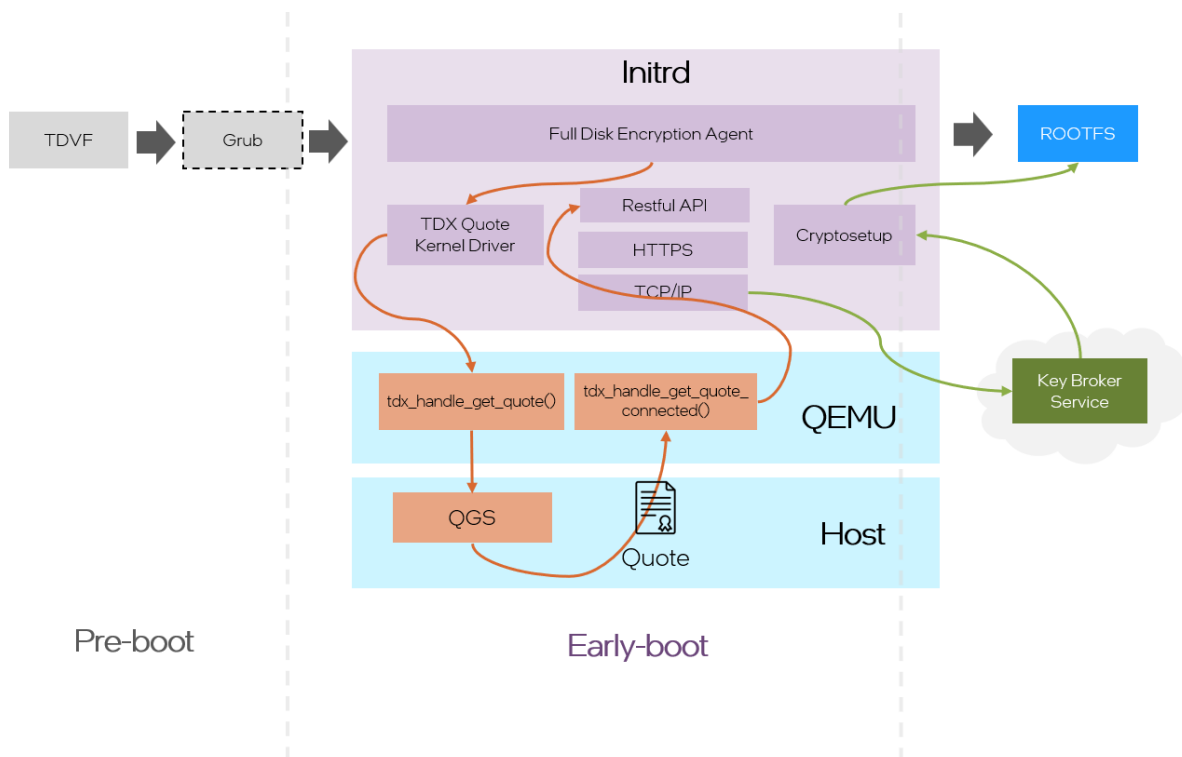

Figure 17: Full Disk Encryption in TDX Guest

The FDE can be done in OVMF at the pre-boot stage or initrd at the Linux early boot stage like. To learn more, refer to the presentation "[Secure Bootloader for Confidential Computing](#)".

#### 3.5.1 Workflow

This section introduces a solution/implementation integrating FDE with Intel TDX. The workflow can be divided into 5 steps.

1. Register key and keyid from the Key Broker Service (KBS).

2. Create an encrypted guest image with key retrieved in Step 1
3. Install FDE components in the encrypted guest image
4. Enroll necessary variables into OVMF
5. Launch a TDX guest based on the encrypted guest image and the OVMF

In the above step 1, the key and keyid pair should be registered in the KBS. Typically, the key will be used to encrypt the guest image, and the keyid is the identifier of the key in the KBS, which will be used in the decryption process. Given that KBS providers have different designs for their keys and keyids, it is recommended to register the pair of the key and the keyid after consulting the KBS provider.

In the above step 2, it creates an encrypted guest image.

In the above step 3, FDE components will be installed in the encrypted guest image. The tdx-tools provides an integrated script "[tdx-tools/attestation/full-disk-encryption/tools/image/fde-image.sh](#)" to complete the task. The key and the keyid is retrieved in Step 1, and the tdx-repo is built from the tdx-tools.

```
$ cd attestation/full-disk-encryption/tools/image
$ ./fde-image.sh -k ${key} -i ${keyid} -d ${tdx-repo}
```

In Step 4, several variables are enrolled in the OVMF. These variables, such as keyid, are retrieved by the fde-agent from the OVMF to help remote attestation retrieve the key from the KBS. For example, assume that the keyid is saved in a JSON file. The python script "[tdx-tools/attestation/full-disk-encryption/tools/image/enroll\\_vars.py](#)" helps enroll the data.

```
$ cd attestation/full-disk-encryption/tools/image
$ # Enroll user data
$ cat userdata.txt
{
  "keyid":"sth"
}
$ NAME="KBSUserData"
$ GUID="732284dd-70c4-472a-aa45-1ffda02caf74"
$ DATA="userdata.txt"
$ python3 tools/image/enroll_vars.py -i OVMF.fd -o OVMF.fd -n $NAME -g $GUID -d $DATA
$ # Enroll KBS URL
$ NAME="KBSURL"
$ GUID="0d9b4a60-e0bf-4a66-b9b1-db1b98f87770"
$ DATA="url.txt"
$ python3 tools/image/enroll_vars.py -i OVMF.fd -o OVMF.fd -n $NAME -g $GUID -d $DATA
$ # Enroll KBS Certificate
$ NAME="KBSCert"
$ GUID="d2bf05a0-f7f8-41b6-b0ff-ad1a31c34d37"
$ DATA="cert.cer"
```



```
$ python3 tools/image/enroll_vars.py -i OVMF.fd -o OVMF.fd -n $NAME -g $GUID -d $DATA
```

In Step 5, a TDX guest is launched from the encrypted guest image. The script “tdx-tools/start-qemu.sh” can launch it. Please use the encrypted guest image and OVMF mentioned in step 3 and step 4.

```
$ OVMF_PATH=/path/to/OVMF
$ IMAGE_PATH=/path/to/image
$ start-qemu.sh \
  -b grub \
  -q tdmcall \
  -o ${OVMF_PATH} \
  -i ${IMAGE_PATH}
```

The detail steps are described in [tdx-tools/doc/full\\_disk\\_encryption.md](#).

### 3.5.2 Prepare Encryption Image

It is complicated to create an encrypted guest image in Step 2 and Step 3. In Step 2, an empty image is created first. The image will be partitioned into several volumes, and the root filesystem partition is encrypted with the key in actual. Then the rootfs is copied to the root filesystem partition.

In the Step 3, a binary named by the fde-agent and its related configuration need to be installed into the initrd. The parameter “cryptdevice=\${root-enc}”, which specifies the encrypted root partition, is appended in the kernel cmdline to enable the FDE.

More details are described in the [tdx-tools/attestation/full-disk-encryption/README.md](#).

# 4 Measurement & Attestation

## 4.1 TEE, TCB, Quote

Typically, a TEE provides the evidence or measurements of its origin and current state so that the evidence can be verified by another party either programmatically or manually. It can decide whether to trust code running in the TEE. It is typically important that such evidence is signed by hardware that can be vouched for by a manufacturer, so that the party checking the evidence has strong assurances that it was not generated by malware or other unauthorized parties. [3] The remote party allows sending the secret or key to the TEE environment after successfully verifying the evidence.

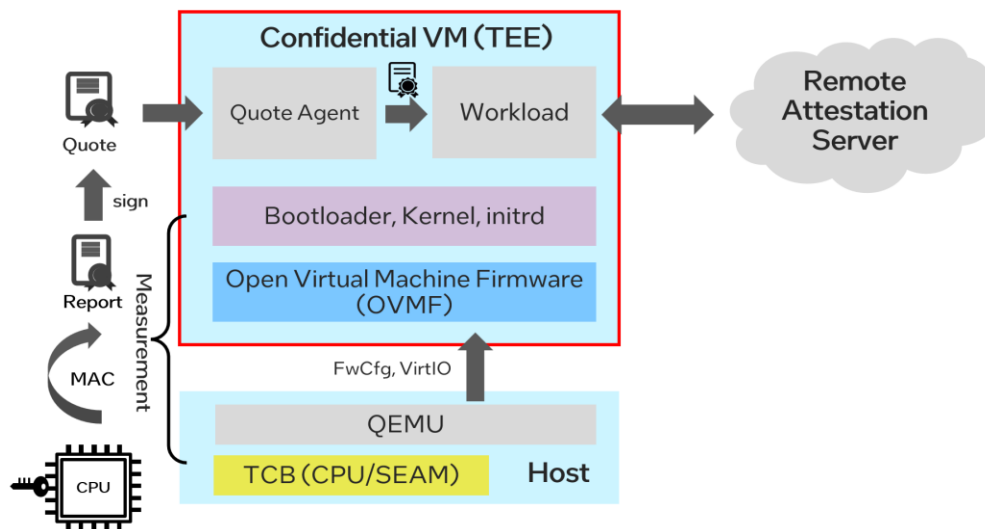

Figure 18: Measurement and Attestation for TEE

The trusted computing base (TCB) refers to all of a system's hardware, firmware, and software components that provide a secure environment. For a confidential VM, it includes hardware information such as CPU, SEAM firmware, and guest components such as OVMF, bootloader (shim/grub), and kernel. The other host software such as QEMU VMM and Orchestrator Libvirt are out of TCB.

The hash-chained measurement on TCB will be extended to some secure registers such as TPM PCR (platform configuration register). The values from several secure registers are constructed to a report and are finally signed to be a quote by an attestation key.

## 4.2 TDX Measurement

### 4.2.1 TD Report

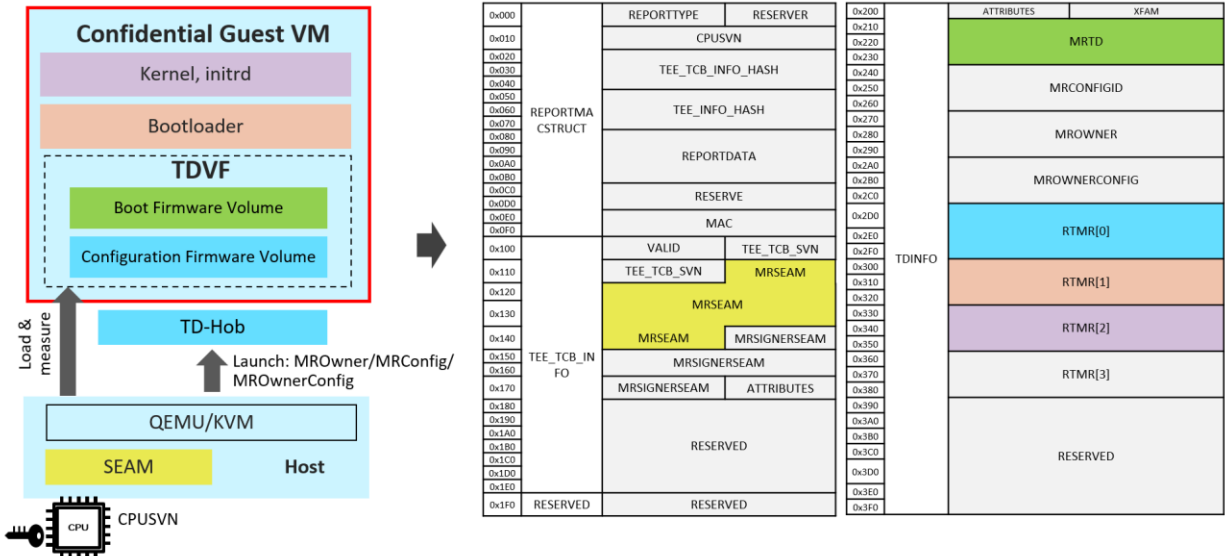

Figure 19: Intel TDX Measurement

The API TDG.MR.REPORT in the Intel TDX module creates a TDREPORT\_STRUCT structure<sup>5</sup> containing the TD measurements, initial configuration of the TD that was locked at finalization (TDH.MR.FINALIZE), the Intel TDX module measurements, and the REPORTDATA value [1]:

- The measurement of TDX module is recorded in the field MRSEAM.
- The measurement of TDVF/OVMF is record in the field MRTD.
- The measurement of TD-Hob, ACPI is record in the RTMR [0].
- The measurement of bootloaders like grub/shim is recorded in the field RTMR [1].
- The measurement of kernel and initrd is recorded in the field RTMR [2].

*NOTE: for direct boot, there is no bootloader, so the measurement of kernel is recorded in the field RTMR [1].*

### 4.2.2 MRTD and RTMR

There are two types of measurement registers – MRTD and RTMR for Intel TDX:

<sup>5</sup> <https://github.com/tianocore/edk2/blob/master/MdePkg/Include/IndustryStandard/Tdx.h>

- MRTD (TD measurement register) provides static measurement of TD build process and the initial contents of TD
- RTMR (runtime measurement register) is an array of general-purpose measurement registers to Intel TDX software to enable measuring additional logic and data loaded into the TD at runtime. As designed, RTMR can be used by the guest TD software to measure boot process.

There are 4 RTMR registers:

*Table 5: RTMR Definitions*

Register	Content	Measured by
RTMR [0]	Static configuration (CFV); Dynamic Configuration (TD HOB, ACPI)	TDVF
RTMR [1]	PCI option ROM, OS loader, OS kernel, initrd, GPT, boot variable, boot parameter	TDVF
RTMR [2]	TD OS App	OS applications
RTMR [3]	Reserved	

### 4.2.3 Pre-Boot Measurement

The pre-boot environment before the kernel includes the TDVF/OVMF phase of the bootloader phase (shim and grub). The whole boot chain will be measured into RTMR via [EFI\\_CC\\_MEASUREMENT\\_PROTOCOL](#)<sup>6</sup>.

<sup>6</sup> <https://github.com/tianocore/edk2/blob/master/MdePkg/Include/Protocol/CcMeasurement.h>

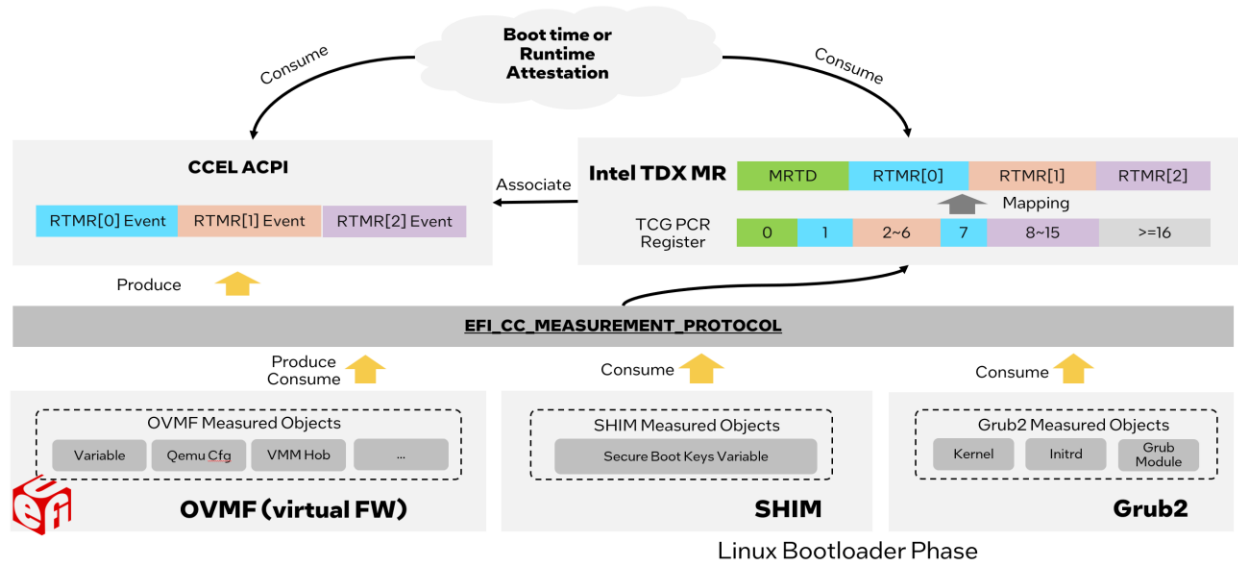

Figure 20: TD Measurement Process

Similar to TCG event log [4], [EFI\\_CC\\_MEASUREMENT\\_PROTOCOL](#) logs the events into ACPI table CCEL<sup>7</sup> and the measurement hash is extended to the corresponding RTMR register. The event logs in CCEL table can be replayed within a TD guest to verify the RTMR value.

#### 4.2.4 PyTdxMeasure Tool

[PyTdxMeasure](#) in `tdx-tools` provides a Python library and utilities for TD measurement that can be used by tenant workload, attestation agent, or validation tools:

- Get RTMR value from TDREPORT via Linux attestation driver.
- Get the full TD event log from CCEL ACPI table.
- Verify value of RTMR by replaying event logs.

Here are the step-by-step instructions to use PyTdxMeasure:

- Install

```
$ python3 -m pip install pytdxmeasure
```

- Run

- Get Event Log.

```
$ ./tdx_eventlogs
```

<sup>7</sup> [https://uefi.org/specs/ACPI/6.5/05\\_ACPI\\_Software\\_Programming\\_Model.html#cc-event-log-acpi-table](https://uefi.org/specs/ACPI/6.5/05_ACPI_Software_Programming_Model.html#cc-event-log-acpi-table)

Refer to the example outputs at [measurement log for grub boot](#) and [measurement log for direct boot](#)

- o Get **TDREPORT**, which includes value of **RTMR**.

```
$ ./tdx_tdreport
```

- o Verify **RTMR**.

```
$ ./tdx_verify_rtmr
```

The tool will compare **RTMR** value from **TDREPORT** and **RTMR** value replayed via event log. The two values are expected to be identical, which means the measured contents are not tampered with.

### 4.2.5 Linux Runtime Measurement

Integrity Measurement Architecture (IMA) is the Linux kernel integrity subsystem to detect if files have been accidentally or maliciously altered, both remotely and locally. Currently IMA maintains the runtime measurement list if anchored in a hardware Trusted Platform Module (TPM) to make the measured hashes of files immutable. It also supports the appraise mechanism to enforce local file integrity by appraising the measurement against a “good” value stored as an extended attribute.

Extra kernel changes have been introduced to enable IMA in TD guest and maintain the runtime measurement list inside RTMR [2].

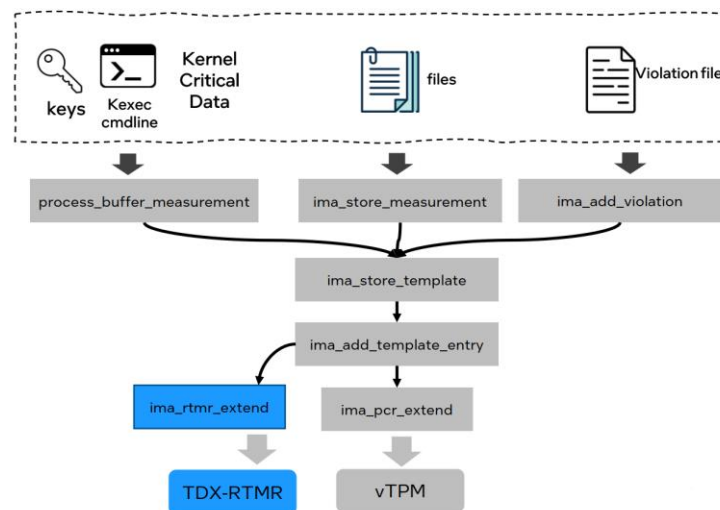

Figure 21: Enable IMA extend hash to RTMR

Different configurations (built-in kernel command line) can be applied to define the scope to be measured. Available options include:

- “`ima_hash=sha384`”: Enable measurement against boot aggregates, which covers firmware, boot loader, kernel command line and etc.
- “`ima_hash=sha384 ima_policy=critical_data`”: Enable measurements against boot aggregates and kernel integrity critical data.
- “`ima_hash=sha384 ima_policy=tcb`”: Enable measurements against all programs executed, files mmap’*d* for execution, and all files opened with the read mode bit set by either the effective uid (`eid=0`) or `uid=0`.

Custom policies can be set by user to define the scope to be measured. For more details, please refer to the IMA documentations.

Below are some sample instructions to enable and verify this feature in a TD guest:

- Sample configuration to start up the TD VM

```
$ ./start-qemu.sh -k <path-to-kernel> -i <path-to-image> -e
"ima_hash=sha384 ima_policy=critical_data"
```

- Run
  - Get IMA measurement count.

```
$ cat /sys/kernel/security/integrity/ima/runtime_measurements_count
```

- Get full IMA measurement list stored inside the kernel securityfs.

```
$ cat /sys/kernel/security/integrity/ima/ascii_runtime_measurements
```

- Verify RTMR within TDREPORT by using the PyTdxMeasure Tool.

```
$ cd tdx-tools/attestation/pytdxmeasure
$ sudo ./tdx_tdreport
```

User can find the measurements extended in RTMR [2] inside the TDREPORT. TPM PCR Calculator (available in Microsoft Store) can be used to replay the result with the ASCII measurements that fetched inside kernel security FS.

## 4.3 Attestation

### 4.3.1 Overview

Remote attestation helps an off-platform party (also known as Relying Party) to have increased confidence that the software is running inside a TD, on a genuine, Intel-TDX system, and at a given security level (also referenced as the TCB version).

On a high level, the Relying Party requests attestation proof – a TD Quote – and then verifies this TD Quote. Among other information, the TD Quote contains: TD

measurements (static and runtime), data that the TD associates with itself, SVNs of elements in the TDX TCB. Intel TDX attestation requires Intel SGX, because an SGX-based TD-Quoting Enclave is used in the process. In the following, we provide some more details of the Intel SGX attestation flow. See Section E of [Intel® Trust Domain Extension – White Paper](#) for more details about Intel TDX remote attestation.

Intel TDX Attestation flow (see Figure 22):

- (1): Relying Party sends an attestation request to TD.
- (2): TD requests a TD Report from the Intel TDX Module
- (3, 4): Intel TDX Module invokes the CPU instruction SEAMREPORT, which triggers the hardware-based generation of a TD Report including, among other information, TD measurements (static and runtime), data that the TD associates with itself, SVNs of elements in the TDX TCB. The SEAMREPORT instruction protects the integrity of the TD Report with a MAC for which the key is only known to hardware.
- (5): Intel TDX Module passes back the TD Report to the TD.
- (6): TD forwards the TD Report to the VMM requesting the conversion to a TD Quote.
- (7, 8): VM forwards the TD Report to the TD Quoting Enclave for conversion. TD Quoting Enclave uses the CPU instruction EVERIFYREPORT2 to verify the MAC of the TD Report. On success, the TD Quoting Enclave converts the TD Report to a TD Quote by signing the TD Report with its Attestation Key. The Attestation Key is signed with the Provisioning Certificate Key (PCK) by the Provisioning Certification Enclave (PCE) and the Intel publishes certificates and certificate revocation lists for PCKs. As a result, the trust of TD Quotes is rooted in Intel CAs.
- (9, 10): VMM passed back TD Quote to TD, and TD forwards it to the challenger.
- (11, 12): Relying Party performs attestation verification by verifying the TD Quote. The attestation verification can be done by the Relying Party itself or using a dedicated attestation service, e.g., Project Amber.

Intel TDX remote attestation demonstrates applications that are running securely on a given trusted environment (TD guest) to a relying party. This increases the confidence of a remote party that the software is running inside a TD on a genuine Intel TDX system at a given security level, which is also referenced as the TCB



version. The TDX attestation reuses Intel SGX infrastructure to provide attestation to a given measurement. It is based on TD Quote, which is the signed TD Report in TD Quoting Enclave [1].

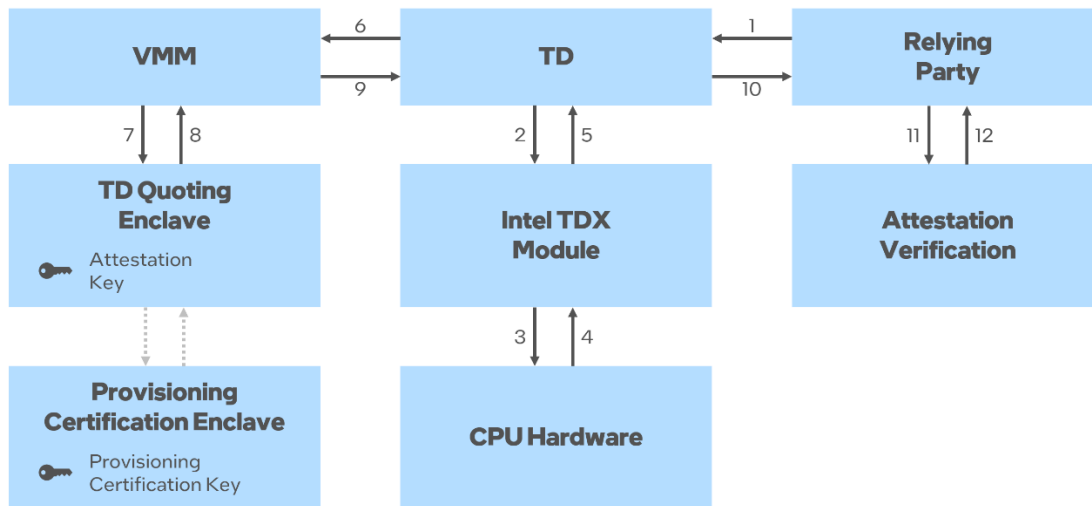

Figure 22: Intel TDX Attestation Flow

Linux Stack for Intel TDX provides end-to-end Intel TDX attestation capability by integrating the Intel® Software Guard Extensions Data Center Attestation Primitives<sup>8</sup> (Intel® SGX DCAP). In this section, it will introduce how to run Intel TDX remote attestation.

### 4.3.2 Set Up DCAP Repository on Host

In the following, we show how to set up Intel SGX DCAP on an Intel TDX host with either Ubuntu 22.04 or RHEL 8.x. For more details about installation and self-building <https://download.01.org/intel-sgx/sgx-dcap/1.17/linux/docs/> or <https://github.com/intel/SGXDataCenterAttestationPrimitives>

Before running the steps, download SGX DCAP archive 1.17 from <https://download.01.org/intel-sgx/sgx-dcap/1.17/linux/> according to your OS distro. The relevant archive is named `sgx_*_local_repo.tgz`.

#### 1. Ubuntu 22.04

```
$ # Switch to root user
$ sudo su
$
$ tar zxvf <sgx_debian_local_repo file name>.tar.gz
$ mv sgx_debian_local_repo /srv/sgx_debian_local_repo
```

<sup>8</sup> <https://github.com/intel/SGXDataCenterAttestationPrimitives>

```

$
$ # Set up local Debian repository
$ cat <<EOF >> /etc/apt/sources.list.d/sgx_debian_local_repo.list
deb [trusted=yes arch=amd64] file:/srv/sgx_debian_local_repo jammy main
EOF
$
$
$ apt update
$ apt install -y gcc make tar

# Install latest nodejs, version 18 shown below is an example
$ curl -sL https://deb.nodesource.com/setup_18.x -o nodesource_setup.sh
$ bash nodesource_setup.sh sudo apt-get install -y nodejs

```

## 2. RHEL 8.x

```

$ # Switch to root user
$ sudo su
$
$ cd /srv/
$ tar zxvf <sgx_rpm_local_repo file name>.tar.gz
$ mv sgx_rpm_local_repo /srv/sgx_rpm_local_repo
$
$ # Set up local RPM repository
$ cat <<EOF >> /etc/yum.repos.d/tdx-attestation.repo
[tdx-attestation-local]
name=tdx-attestation-local
baseurl=file:///srv/sgx_rpm_local_repo
enabled=1
gpgcheck=0
module_hotfixes=true
EOF
$
$ dnf check-update
$ dnf install -y gcc make tar

$ sudo dnf module reset nodejs
$
$ # Install latest nodejs, version 18 shown below is an example
$ dnf module install nodejs:18

```

### 4.3.3 Set Up PCCS on Host

Intel provides a reference implementation of the Provisioning Certification Caching Service (PCCS). This cache can store collateral (e.g., Provisioning Certificate Key certificates and TCB levels) necessary for TD quote generation and TD quote verification, without the need to access the Intel® Software Guard Extensions Provisioning Certification Service (Intel® SGX PCS).

In the following example, we assume you use Intel's PCCS implementation for remote attestation purposes.

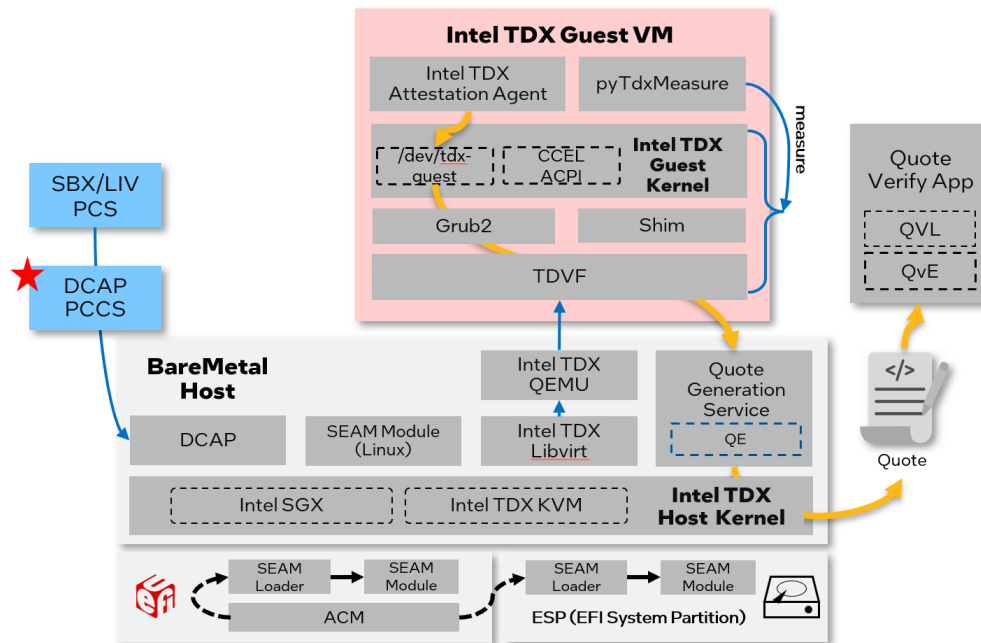

Figure 23: Setup PCCS

1. If you do not have an API key for the Intel SGX PCS service, obtain a key:  
Go to <https://api.portal.trustedservices.intel.com/provisioning-certification> login (or create an account), and click 'Subscribe'. Two API keys are generated (for key rollover). Copy one of the API keys for the following steps.
2. Install PCCS with following steps. During installation, answer “Y” when asked if the PCCS should be installed now, “Y” when asked if PCCS should be configured now, and enter API key generated in step 1 when asked for “Intel PCS API key”. Answer the remaining questions according to your needs.

- For Ubuntu 22.04

```

$ # Switch to root user for installation
$ sudo su
$
$ apt update
$ apt install -y --no-install-recommends sgx-dcap-pccs
$ cd /opt/intel/sgx-dcap-pccs
$ sudo -u pccs ./install.sh

```

- For RHEL 8.x

```

$ # Switch to root user for installation
$ sudo su
$
$ dnf install -y sgx-dcap-pccs
$ cd /opt/intel/sgx-dcap-pccs
$ sudo -u pccs ./install.sh

```

3. After the installation is completed successfully, make sure the PCCS is configured to use the v4 API. Look for "uri" in the configuration file /opt/intel/sgx-dcap-pccs/config/default.json:

```

"uri": "https://api.trustedservices.intel.com/sgx/certification/v4/"

```

4. If present, delete the old PCCS database. Afterwards, restart PCCS.

```

$ $ [Optional] Remove old PCCS datase
$ sudo rm -rf /opt/intel/sgx-dcap-pccs/pckcache.db
$
$ Restart PCCS and check status
$ sudo systemctl restart pccs
$ sudo systemctl status pccs

```

You can check the service log of the PCCS service with the following command:

```

$ sudo journalctl -u pccs -f

```

### 4.3.4 Set Up Quote Generation Service on Host

This section introduces how to install Quote Generation Service (QGS) and how to perform Intel SGX platform registration.

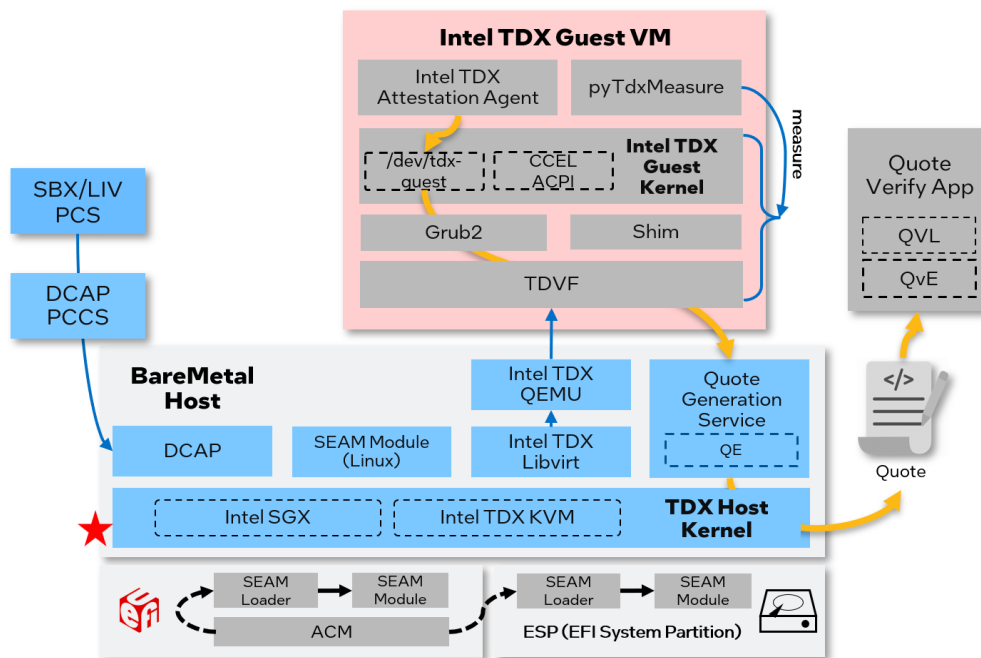

Figure 24: Set up DCAP software on the TDX host

1. Download the Intel® Software Guard Extensions SDK for Linux\* OS (Intel® SGX SDK for Linux\* OS) from <https://download.01.org/intel-sgx/sgx-dcap/1.17/linux/distro/> according to your OS distro. The relevant archive is named `sgx_linux_x64_sdk_*.bin`.
2. Install the Intel® Software Guard Extensions SDK for Linux\* OS (Intel® SGX SDK for Linux\* OS) to the folder `/opt/intel/`

- For Ubuntu 22.04

```
$ sudo ./sgx_linux_x64_sdk_2.20.100.4.bin
```

- For RHEL 8.x

```
$ sudo ./sgx_linux_x64_sdk_2.20.100.4.bin
```

2. Install QGS and QPL packages on the host.

- For Ubuntu 22.04

```
$ sudo apt install -y --no-install-recommends tdx-qgs libsgx-dcap-default-qpl libsgx-dcap-default-qpl-dev
```

- For RHEL 8.x

```
$ sudo dnf install -y tdx-qgs libsgx-dcap-default-qpl libsgx-dcap-default-qpl-devel
```

Modify the configuration file: `/etc/sgx_default_qcnl.conf` to add the following. Replace `<PCCS_IP>` with the IP of your PCCS.

```
// PCCS server address
"pccs_url": "https://<PCCS_IP>:8081/sgx/certification/v4/",
// To accept insecure HTTPS certificate depends on PCCS Server's configuration,
// set below option to false
"use_secure_cert": false
```

3. Install PCKIDRetrievalTool

- For Ubuntu 22.04

```
$ sudo apt install -y sgx-pck-id-retrieval-tool
```

- For RHEL 8.x

```
$ sudo dnf install -y sgx-pck-id-retrieval-tool
```

*NOTE: the reported version of the PCKIDRetrievalTool may be different.*

4. Modify the configuration file `/opt/intel/sgx-pck-id-retrieval-tool/network_setting.conf` with the following content.

```
PCCS_URL=https://<PCCS_IP>:8081/sgx/certification/v4/platforms
# if using localhost as pccs
```

```
# PCCS_URL=https://localhost:8081/sgx/certification/v4/platforms
USE_SECURE_CERT=FALSE
```

### 5. Perform SGX platform Registration via PCKIDRetrievalTool

```
$ cd /opt/intel/sgx-pck-id-retrieval-tool
$ sudo sh -c ./PCKIDRetrievalTool
```

The expected response is as follows. The reported version may be different.

```
Intel® Software Guard Extensions PCK Cert ID Retrieval Tool Version 1.17.100.4
Registration status has been set to completed status. Pckid_retrieval.csv has been
generated successfully!
```

*NOTE: If it returns a message like “Platform Manifest not available”, you may need to perform SGX Factory Reset in BIOS and run PCKIDRetrievalTool again.*

### 4.3.5 Generate Quote in TD

This section introduces the generation of a TD quote inside a TD including the launch of a TD with quote generation.

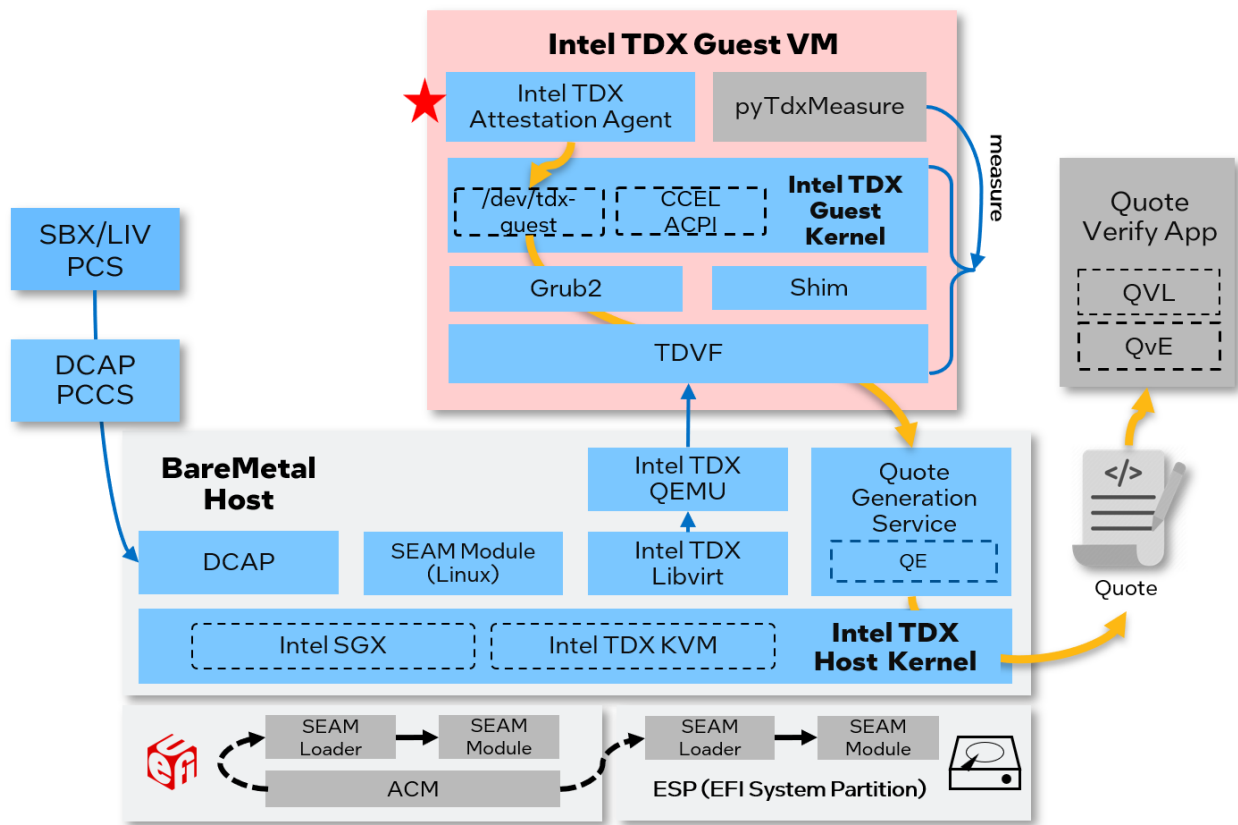

Figure 25: Quote Generation

### 4.3.5.1 Launch TD with Quote Generation Support

There are two ways to run quote generation:

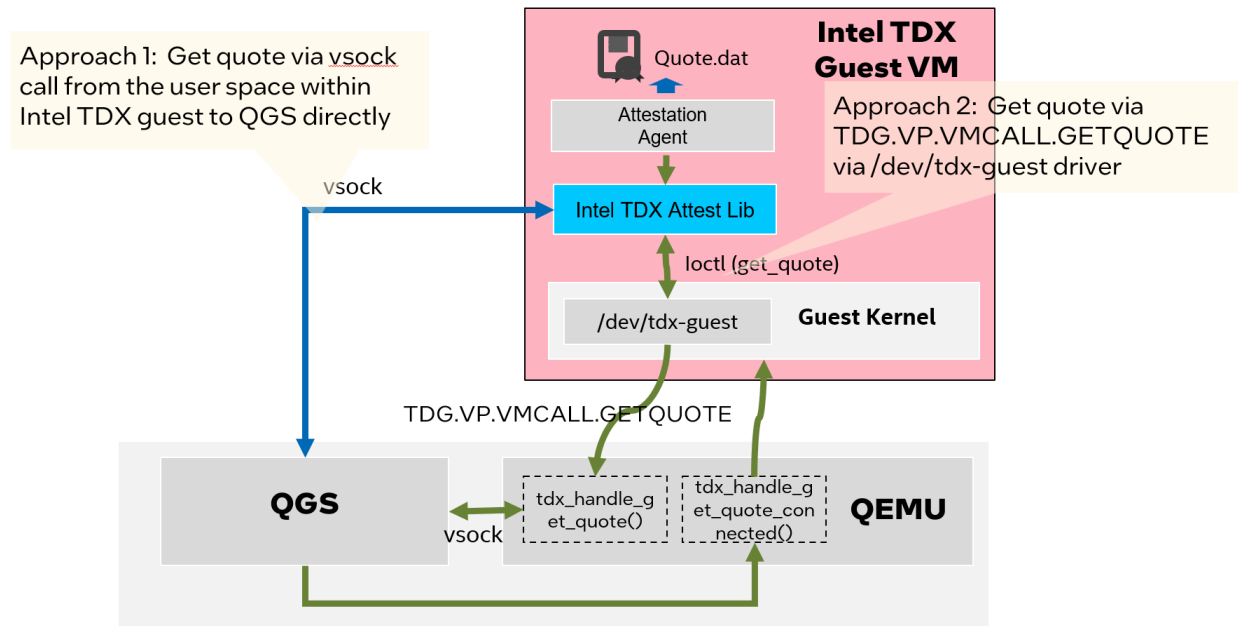

Figure 26: Approaches to Generate Intel TDX Quote

- Approach 1: Get quote via vsock call from the user space within TD guest to QGS directly.
  - If launched via QEMU, add the following parameter.

```
-device vhost-vsock-pci,guest-cid=3
```

- If using start-qemu.sh to indicate getting quote via vsock.

```
$ ./start-qemu.sh -i <guest image> -k <guest kernel> -q vsock
```

- If launched via libvirt, add the following fields in XML

```
<vsock model='virtio'>
  <cid auto='yes' address='3' />
  <address type='pci' domain='0x0000' bus='0x05' slot='0x00' function='0x0' />
</vsock>
```

- Approach 2: Get quote via TDG.VP.VMCALL.GETQUOTE
  - If launched via QEMU, add “quote-generation-service=vsock:2:4050” in parameter -object

```
-object tdx-guest,sept-ve-disable,id=tdx,quote-generation-service=vsock:2:4050
```

- If using start-qemu.sh to indicate getting quote via tdvncall.

```
$ ./start-qemu.sh -i <guest image> -k <guest kernel> -q tdvncall
```

- If launched via Libvirt, add following fields in XML

```
<launchSecurity type='tdx'>
  .....
  <Quote-Generation-Service>vsock:2:4050</Quote-Generation-Service>
</launchSecurity>
```

- Within a TD guest, create a file at `/etc/tdx-attest.conf` with the following content:

```
port=4050
```

#### 4.3.5.2 Generate Quote within Intel TDX Guest

1. Set up the package repository in TD guest. Refer to Section 4.3.2: Set Up DCAP.

- Install `libtdx-attest`, `libtdx-attest-dev`
  - For Ubuntu 22.04

```
$ sudo apt install -y libtdx-attest libtdx-attest-dev
```

- For RHEL 8.x

```
$ sudo dnf install -y libtdx-attest libtdx-attest-devel
```

2. Build quote generation sample

- For Ubuntu 22.04

```
$ sudo apt install -y gcc make
$ cd /opt/intel/tdx-quote-generation-sample/
$ make clean
$ make
```

- For RHEL 8.x

```
$ sudo dnf install -y gcc make
$ cd /opt/intel/tdx-quote-generation-sample/
$ make clean
$ make
```

3. Use `test_tdx_attest` to generate TD quote which will be written into file `quote.dat`.

```
$ sudo ./test_tdx_attest
```

#### 4.3.6 Verify TD Quote on Host



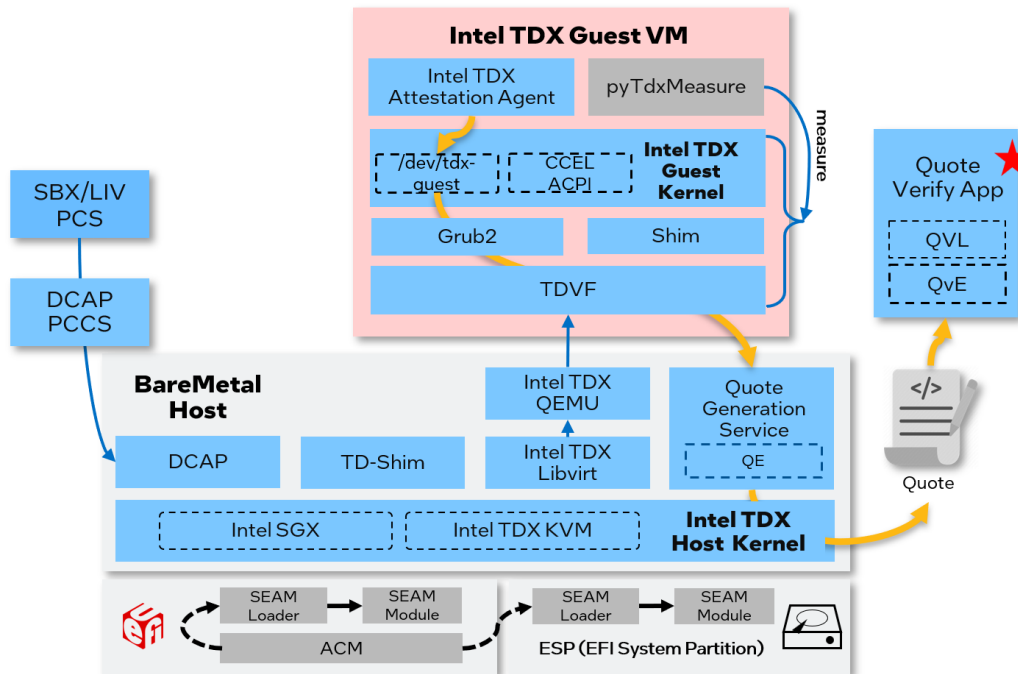

Figure 27: Verify Quote

After the Quote is generated, you can use a sample Quote verification application to verify the Quote.

1. Install the Quote verification libraries:

- o For Ubuntu 22.04

```
$ sudo apt install -y libsgx-dcap-quote-verify
$ sudo apt install -y libsgx-dcap-quote-verify-dev
$ sudo apt install -y libsgx-ae-qve
```

- o For RHEL 8.x

```
$ sudo dnf install -y libsgx-dcap-quote-verify
$ sudo dnf install -y libsgx-dcap-quote-verify-devel
$ sudo dnf install -y libsgx-ae-qve
```

2. Copy `quote.dat` from TDVM

Use `scp` or `virt_copy_out` to copy the quote from the TDVM.

```
$ # use scp to copy the quote from TDVM to host
$ scp <TDVM-user>@<TDVM-IP>:<path-to>/quote.dat <host_directory>/.
$ # use virt-copy-out to copy the quote from TDVM to host
$ virt-copy-out -a <image_name> <directory_in_TDVM_contains_quote.dat>
<a_host_directory>
```

**NOTE:** Terminate the TDVM before using `virt_copy_out` to copy out the `quote.dat`.

3. Build and run sample application verifying the generated quote located at <PATH>:

```
$ git clone https://github.com/intel/SGXDataCenterAttestationPrimitives.git
$ cd SGXDataCenterAttestationPrimitives/SampleCode/QuoteVerificationSample
$ make SGX_DEBUG=1
$ ./app -quote <PATH>/quote.dat
```

## 4.4 Use Intel Project Amber

Intel Project Amber is Intel's first step in creating a new multi-cloud, multi-TEE service for third-party attestation to help drive forward adoption of confidential computing for the broader industry. Please refer to [Project Amber](#) for more details. This section introduces how to install the Amber client to access services.

### 4.4.1 Overview

Intel® Project Amber Go Client Library<sup>9</sup> is a Go library for integrating with the Intel® Project Amber V1 API. A beta version Intel® Project Amber Go TDX CLI<sup>10</sup> (amber-cli) is also provided in this library repository. This amber-cli provides basic functionalities:

- Create RSA key pair
- Get an Amber signed token
- Get a TD Quote with nonce and user data
- Decrypting an encrypted blob

This section introduces the installation and example usages.

### 4.4.2 Installation

A build script is provided by tdx-tools. Refer to 2.4.1 Build Packages to build packages and 2.5 Install IaaS Host to set up the repository.

*NOTE: This package is only for TD guest's attestation environment. The packages will be installed by default if the guest image is created using guest image tool in 2.4.2 Create Guest Image.*

- In case the packages are not installed by default, install the Amber Client package and its dependency.

---

<sup>9</sup> <https://github.com/intel/amber-client>

<sup>10</sup> <https://github.com/intel/amber-client/tree/main/amber-cli-tdx>

- For Ubuntu 22.04

```
$ sudo apt install -y libtdx-attest amber-cli
```

- For RHEL 8.x

```
$ sudo dnf install libtdx-attest intel-mvp-amber-cli
```

### 4.4.3 Example Usage

To get the TD Quote, a nonce and user data can be used as input parameter.

- Get a TD Quote

```
$ amber-cli quote
```

- The nonce is a value constructed to be unique to a particular message to prevent replay attacks, user can get a nonce from Amber attestation service or create random data as a nonce. To get a TD Quote with the nonce by following step, the hash of the nonce will be put into TD report in the TD Quote.

```
$ amber-cli quote --nonce <base64 encoded nonce>
```

- Get a TD Quote with nonce and user data

```
$ amber-cli quote --nonce <base64 encoded nonce> --user-data <base64 encoded userdata>
```

To get an Amber signed token, the [AMBER\\_URL](#) and [AMBER\\_API\\_KEY](#) is needed, please contact Intel® Project Amber team to get them.

- Export environment variables

```
$ export AMBER_URL=<amber api url>
$ export AMBER_API_KEY=<amber attestation api key>
```

- Create RSA key pair

```
$ amber-cli create-key-pair --key-path <private key file path>
```

- Get an Amber signed token

```
$ amber-cli token
```

- Get an Amber signed token with user data and policy-ids

```
$ amber-cli token --user-data <base64 encoded userdata> --policy-ids <comma separated amber attestation policy ids>
```

The `amber-cli` provides a feature to decrypt an encrypted blob. The encrypted blob should be encoded by base64.

```
$ amber-cli decrypt --key-path <private key file path> --in <base64 encoded  
encrypted blob> --out <output file path>
```

# 5 Validation

## 5.1 Overview

The Linux Stack for Intel TDX provides end to end TDX capability across diverse infrastructures like hypervisor and Kubernetes within hypervisor.

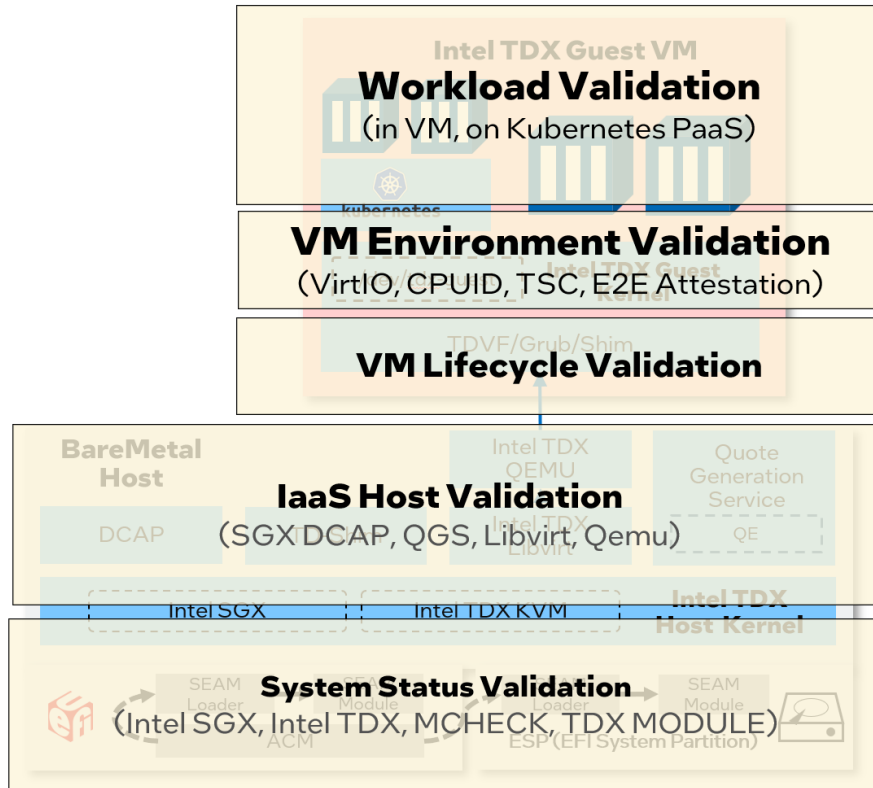

Figure 28: Intel TDX E2E Full Stack Validation

The end-to-end validation of Linux Stack for Intel TDX covers the following scopes.

Table 6: Linux Stack for Intel TDX Validations

Validation	Scope	Description
System Status	IaaS	Verify the hardware and BIOS status like Intel SGX, Intel TME-MK, Intel TDX, Intel TDX module, etc.
IaaS Host	IaaS	Verify the functionality of IaaS components like platform registration, QGS service, libvirt and QEMU configurations
VM Lifecycle	PaaS	Diverse boot types for TD VM guest, pre-boot environment measurement, etc.

<b>VM Environment</b>	PaaS	CPUID, TSC, VirtIO devices, etc.
<b>Workload</b>	PaaS	Container workloads run in TD guest or the Kubernetes cluster within TD guest

To support complex validation and automation scenarios, the pyCloudStack framework is designed to support the scopes mentioned in Table 6: Linux Stack for Intel TDX Validations.

## 5.2 PyCloudStack

### 5.2.1 Overview

PyCloudStack abstracts the common objects, operations, and resources for diverse cloud architectures. It supports hypervisor stacks based on libvirt or direct QEMU commands, container stacks orchestrated by Kubernetes or directly by docker, and supports running on local or remote IaaS hosts. It can be used to create an advanced deployment CI/CD operator via a Python plugin for ansible, end-to-end validation, framework with customized components and configurations in a full vertical stack.

The overall architecture diagram is illustrated as below:

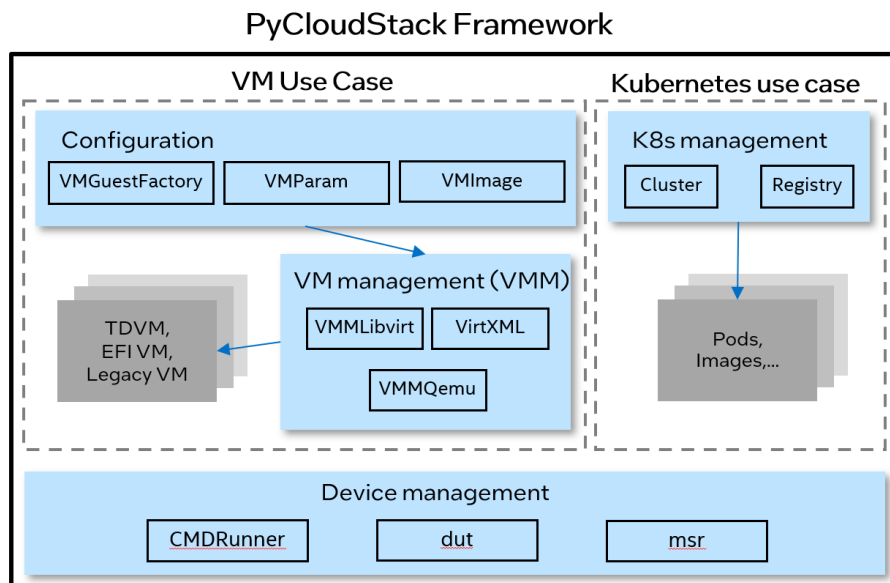

Figure 29: PyCloudStack Framework

The framework supports scenarios for VM management: via QEMU direct or via libvirt:

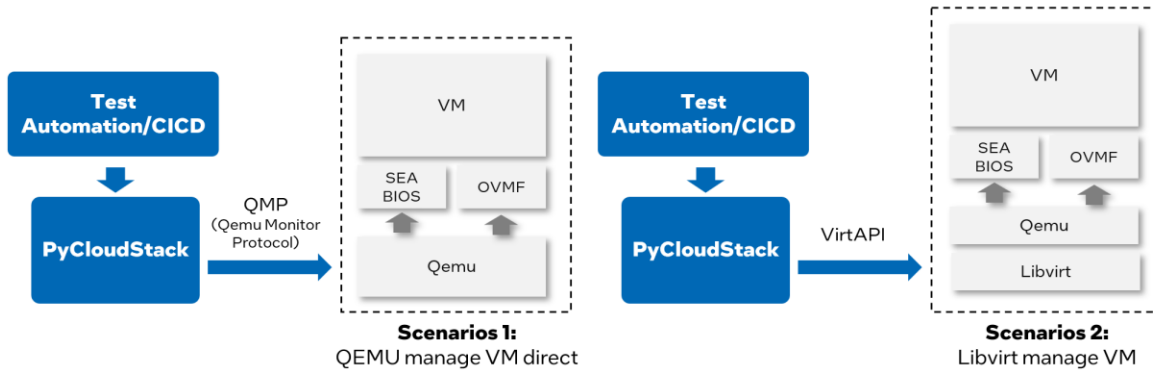

Figure 30: Validation Scenarios for VMM and Libvirt

- Scenario 1: QEMU managed VM directly via QMP (QEMU monitor protocol)<sup>11</sup>
- Scenario 2: Libvirt managed VM via VirtAPI<sup>12</sup>

The framework abstracts the common operations for host, virtual machine, kubernetes, and container:

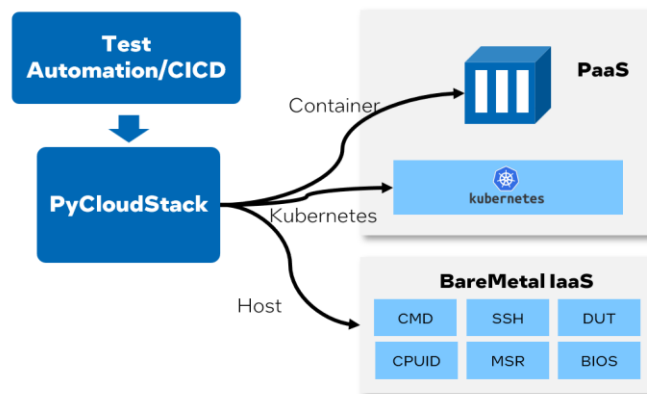

Figure 31: Abstract Common Operations for Cloud Stack

Below are additional details for the VM use case.

- [VMGuestFactory](#) is designed to communicate and handle VM configurations with test cases. For example, the size of a virtual machine can be specified by indicating how many CPUs and how much memory are required. [VMGuestFactory](#) usually works with [VMPParam](#) and [VMImage](#).
  - [VMPParam](#) operator provides predefined VM parameters for typical configuration. It also provides the capability for you to customize VM parameters.

<sup>11</sup> <https://wiki.QEMU.org/Documentation/QMP>

<sup>12</sup> <https://github.com/virtapi/virtapi>

- **VMImage** is designed to manage guest images for guest VMs so that multiple guest distros can be supported. You can customize guest images based on test requirement.
- **VMM** operators are responsible for VM lifecycle management using given configuration. VMM operator includes **VMMLibvirt** and **VMMQEMU**. **VMMLibvirt** needs to work together with “**virtXML**” operator.
- **virtXML** is responsible for Libvirt XML template management. It helps you to customize XML template for VMs.

For Kubernetes use case:

- **cluster** operator is designed to implement Kubernetes object management. **Registry** is used to manage container images. With them working together, you can create Kubernetes objects, such as deployment and service. Then cloud workload can run in a Kubernetes cluster.

There are also some other common operators for Device management at the bottom of the diagram.

- **CMDRunner** is designed to run commands on local host or remote targets via ssh connection.
- **DUT** is designed to manage devices under test, such as CPU frequency of host.
- **MSR** operator provides methods to read and write register.

Finally, with the PyCloudStack framework, functionality, stability, performance, and interoperability tests are well supported.

## 5.2.2 Installation

PyCloudStack has been uploaded to [PyPI](#). Install PyCloudStack to the host via the following command.

```
$ pip3 install pycloystack
```

## 5.2.3 Example

Most of automation tests in the tdx-tools repo are based on the PyCloudStack framework. Below are several examples:

- Example 1: Operate VM via Libvirt

```
from pycloystack.vmguest import VMGuestFactory
```



```

from pycldstack.vmparam import VM_STATE_SHUTDOWN, VM_STATE_RUNNING,
VM_STATE_PAUSE, VM_TYPE_TD

vm_factory = VMGuestFactory(vm_image, vm_kernel)

LOG.info("Create TD guest")
inst = vm_factory.new_vm(VM_TYPE_TD, auto_start=True)
inst.wait_for_ssh_ready()

LOG.info("Suspend TD guest")
inst.suspend()
ret = inst.wait_for_state(VM_STATE_PAUSE)
assert ret, "Suspend timeout"

LOG.info("Resume TD guest")
inst.resume()
ret = inst.wait_for_state(VM_STATE_RUNNING)
assert ret, "Resume timeout"

```

- Example 2: Customize the VM

```

import logging
import psutil
# Get host total cores and sockets, assign 80% vcpu and 80% memory to vm
total_core = psutil.cpu_count()
cores = int(total_core * 0.4)
memsize = int(psutil.virtual_memory().available / 1000 * 0.8)
vmspec = VMSpec(sockets=2, cores=cores, memsize=memsize)
inst = vm_factory.new_vm(VM_TYPE_TD, vmspec=vmspec, auto_start=True)

```

- Example 3: Run TensorFlow AI microbench boosted by AMX within TDVM

```

LOG.info("Create TD guest to test tensorflow")
td_inst = vm_factory.new_vm(vm_type, vmspec=VMSpec.model_large())

# customize the VM image
td_inst.image.inject_root_ssh_key(vm_ssh_pubkey)

# create and start VM instance
td_inst.create()
td_inst.start()
td_inst.wait_for_ssh_ready()

# It may take up to 30 minutes to complete the test
LOG.info("==== The test running may take up to 30 minutes! =====")

command = '''
cd /root/models-2.5.0 && DNNL_MAX_CPU_ISA=AVX512_CORE_AMX OMP_NUM_THREADS=16
KMP_AFFINITY=granularity=fine,verbose,compact
python3 ./benchmarks/launch_benchmark.py
    --model-name dien --mode inference --precision bfloat16
    --framework tensorflow --data-location /root/dien
    --exact-max-length=100 --num-inter-threads 1 --num-intra-threads 16
    --batch-size 8 --graph-type=static
    --in-graph /root/dien_fp32_static_rnn_graph.pb
    --benchmark-only --verbose --
'''

```

```
runner = td_inst.ssh_run(command.split(), vm_ssh_key)
assert runner.retcode == 0, "Failed to execute remote command"

# throughput should not be 0
patt_ok = r'Approximate accelerator performance in recommendations/second is
(\d*\.\d*)'
match = re.search(patt_ok, '\n'.join(runner.stdout))
assert match is not None
images_per_s = match.group(1)
LOG.info('Throughput: %s recommendations/s', images_per_s)
assert float(images_per_s) > 0
```

## 5.3 Intel TDX Tests

Intel TDX tests from tdx-tools are designed to cover basic acceptance tests, functionality, workload, and environment tests for Intel TDX. It also provides interoperability tests by using AMX in an Intel TDX guest VM.

*NOTE: The tests implementation depends on the PyCloudStack framework. The test execution must be on an Intel TDX-enabled Linux platform with an Intel TDX-enabled kernel with QEMU and Libvirt installed.*

*NOTE: Please make sure to use the correct tag of tdx-tools which matches the release version so that the tests can work with different Intel TDX kernel and Intel TDX QEMU versions.*

### 5.3.1 Overview

The tests can be classified into 4 categories – Lifecycle, Environment, Workload and Interoperability. Refer to the test list in the table below. Some of the tests require a customized guest image before running the test. The required prerequisites are in the next section.

Table 7: TDX Stack Tests

Category	Test case	Description
Lifecycle	test_tdvmlifecycle.py	TD lifecycle management
	test_multiple_tdvms.py	Co-existence of multiple TDs
	test_vm_coexists.py	Co-existence Of TD and legacy VM
	test_max_cpu.py	Boot TD with high CPU utilization
	test_vm_shutdown_mode.py	Different shutdown modes of Libvirt
	test_acpi_reboot.py	TD ACPI reboot
	test_acpi_shutdown.py	TD ACPI shutdown
	test_vm_shutdown_qga.py	VM shutdown via QEMU guest agent

	test_vm_reboot_qga.py	VM reboot via QEMU guest agent
<b>Environment</b>	test_tdvm_tsc.py	TD TSC clock source and frequency
	test_tdx_guest_status.py	TDX initialization in TD guest
	test_tdx_host_status.py	Check TDX host status
	test_tdvm_network.py	Check network functions in TD
<b>Workload</b>	test_workload_redis.py	Redis workload running in TD
	test_workload_nginx.py	Nginx workload running in TD
<b>Interoperability</b>	test_amx_docker_tf.py	Run AI model with AMX in docker container on TD
	test_amx_vm_tf.py	Run AI model with AMX in TD

A full example for a redis workload test case is as follows.

```
def test_tdvm_redis(vm_factory, vm_ssh_pubkey, vm_ssh_key):
    """
    Run redis benchmark test
    Ref: https://redis.io/topics/benchmarks
    Use official docker images redis:latest
    Test Steps:
    1. start VM
    2. Run remote command "systemctl status docker" to check docker service's
    status
    3. Run remote command "systemctl start docker" to force start docker service
    4. Run remote command "/root/bat-script/redis-bench.sh"
    to launch redis container and benchmark testing
    """
    LOG.info("Create TD guest to run redis benchmark")
    td_inst = vm_factory.new_vm(VM_TYPE_TD)

    # customize the VM image
    td_inst.image.inject_root_ssh_key(vm_ssh_pubkey)
    td_inst.image.copy_in(
        os.path.join(CURR_DIR, "redis-bench.sh"), "/root/")

    # create and start VM instance
    td_inst.create()
    td_inst.start()
    td_inst.wait_for_ssh_ready()

    command_list = [
        'systemctl start docker',
        '/root/redis-bench.sh -t get,set'
    ]
    for cmd in command_list:
        LOG.debug(cmd)
        runner = td_inst.ssh_run(cmd.split(), vm_ssh_key)
        assert runner.retcode == 0, "Failed to execute remote command"
```

## 5.3.2 Prerequisites

A guest image is required for all the tests. Refer to “Chapter 2.4.2 Create Guest Image” to generate a basic guest image. Additional prerequisites are required for some of the tests. The first step is to start a VM using the guest image built above and go through corresponding items required by tests. The next step is to shut down the VM and use the guest image for further tests.

1. Install QEMU guest agent in guest image.

For Ubuntu 22.04 guest image:

```
$ sudo apt-get install qemu-guest-agent
```

For RHEL 8.x guest image:

```
$ sudo dnf install qemu-guest-agent
```

2. Install docker in guest image.

For Ubuntu 22.04 guest image:

```
$ sudo apt-get install docker.io
```

For RHEL 8.x guest image:

```
$ sudo dnf install docker
```

3. For workload tests, make sure the latest docker image is in the guest image. It needs both the docker image “nginx:latest” and “redis:latest”.

```
$ docker pull nginx:latest  
$ docker pull redis:latest
```

4. Install [intel-tensorflow-avx512](#) in guest image. Download the DIEN\_bf16 model and put it under /root in the guest image.

For ubuntu 22.04 guest image:

```
$ pip3 install intel-tensorflow-avx512==2.11.0  
$ wget https://storage.googleapis.com/intel-optimized-tensorflow/models/v2_5_0/dien_bf16_pretrained_opt_model.pb
```

For RHEL 8.x guest image, upgrade python to python 3.8 first and then run the following commands:

```
$ pip3 install intel-tensorflow-avx512==2.11.0
$ wget https://storage.googleapis.com/intel-optimized-tensorflow/models/v2_5_0/dien_bf16_pretrained_opt_model.pb
```

### 5.3.3 Setup Environment

1. Install required packages:

If your host distro is Ubuntu 22.04:

```
$ sudo apt install python3-virtualenv python3-libvirt libguestfs-dev libvirt-dev python3-dev net-tools
```

If your host distro is RHEL 8.x:

```
$ sudo dnf install python3-virtualenv python3-libvirt libguestfs-devel libvirt-devel python3-devel gcc gcc-c++
```

2. Make sure the libvirt service is started. If not, start libvirt service. If the host is Ubuntu 22.04 and AppArmor is enabled, set `security_driver = "none"` in `/etc/libvirt/QEMU.conf` and restart the libvirt service.

```
$ sudo systemctl status libvirtd
$ sudo systemctl restart libvirtd
```

3. Setup environment. Run the below command to setup the python environment.

```
$ cd tdx-tools/tests/
$ source setupenv.sh
```

4. Create artifacts.yaml from template

Refer template `<tdx-tools>/tests/artifacts.yaml.template` to create `<tdx-tools>/tests/artifacts.yaml`. Update the source and sha256sum to indicate the location of guest image and guest kernel. See following example:

```
latest-guest-image-rhel:
  source: http://cpss-devops.sh.intel.com/download/tdx-guest/latest/td-guest-rhel8.7.qcow2.tar.xz
  sha256sum: http://css-devops.sh.intel.com/download/tdx-guest/latest/td-guest-rhel8.7.qcow2.tar.xz.sha256sum

latest-guest-kernel-rhel:
  source: http://css-devops.sh.intel.com/download/tdx-guest/latest/vmlinuz-rhel8.7
  sha256sum: http://css-devops.sh.intel.com/download/tdx-guest/latest/vmlinuz-rhel8.7.sha256sum
```

```
latest-guest-image-ubuntu:
  source: http://css-devops.sh.intel.com/download/tdx-guest/latest/td-guest-ubuntu-22.04-test.qcow2.tar.xz
  sha256sum: http://css-devops.sh.intel.com/download/tdx-guest/latest/td-guest-ubuntu-22.04-test.qcow2.tar.xz.sha256sum

latest-guest-kernel-ubuntu:
  source: http://css-devops.sh.intel.com/download/tdx-guest/latest/vmlinuz-jammy
  sha256sum: http://css-devops.sh.intel.com/download/tdx-guest/latest/vmlinuz-jammy.sha256sum
```

## 5. Generate keys

Generate a pair of keys that will be used in test running.

```
$ ssh-keygen
```

The keys should be named "vm\_ssh\_test\_key" and "vm\_ssh\_test\_key.pub" and located under tdx-tools/tests/tests/

### 5.3.4 Run Tests

#### 1. Run all tests:

```
$ sudo ./run.sh -s all
$ # NOTE:
$ # "sudo" is required since some tests need root permission.
$ # The user needs to be added into the libvirt group. e.g., for user "root"
$ # please run
$ sudo usermod -aG libvirt root
```

#### 2. Run some case modules:

```
$ ./run.sh -c <test_module1> -c <test_module2>
```

For example, run the whole test module "test\_tdvmlifecycle.py".

```
$ ./run.sh -c tests/test_tdvmlifecycle.py
```

#### 3. Run specific test cases:

```
$ ./run.sh -c <test_module1> -c <test_module1>::<test_name>
```

For example, run the test case "test\_tdvmlifecycle\_virsh\_start\_shutdown" in "tests/test\_tdvmlifecycle.py"

```
$ ./run.sh -c tests/test_tdvmlifecycle.py::
test_tdvmlifecycle_virsh_start_shutdown
```

4. User can specify guest image OS type with “-g”. Currently “rhel” and “ubuntu” are supported. Ubuntu 22.04 guest image will be used by default if “-g” is not specified.

For example, run all the tests using an RHEL 8.x guest image.

```
$ sudo ./run.sh -g rhel -s all
```

# 6 Develop & Debug

## 6.1 Override the Intel TDX module

Secure arbitration mode (SEAM) is an extension to the virtual machines extension (VMX) architecture to define a new VMX root operation called SEAM VMX root and a new VMX non-root operation called SEAM VMX non-root. Collectively, the SEAM VMX root and SEAM VMX non-root execution modes are called operations in SEAM. SEAM VMX root operation is designed to host a CPU-attested, software module called the Intel® Trust-Domain Extensions (Intel® TDX) module to manage virtual machine (VM) guests called Trust Domains (TD). Currently, the Intel TDX Module is the only SEAM module that the Intel P-SEAM LDR installs [1].

By default, BIOS loads the built-in version of TDX Loader and TDX module from the IFWI during the server booting. For development or upgrading purpose without re-flashing the BIOS, a debug or new version SEAMLDR and TDX module could be placed into the ESP partition. The BIOS loads the new or debug version from ESP on the next boot.

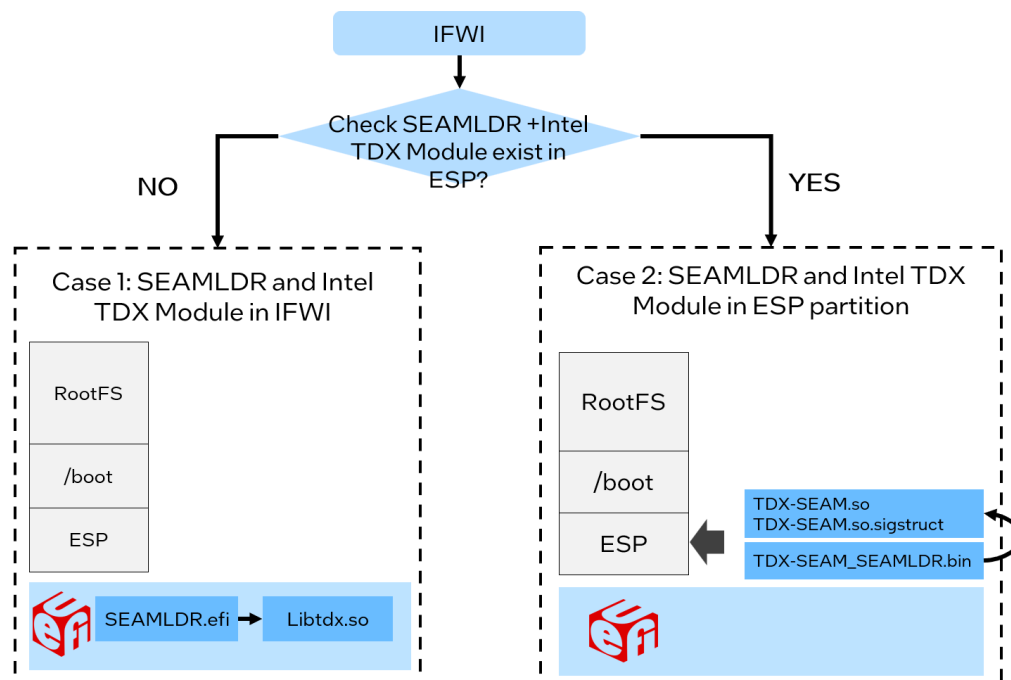

Figure 32: BIOS Search TDX Module from ESP

The naming rule is:



- <ESP>/EFI/TDX/TDX-SEAM\_SEAMLDR.bin
- <ESP>/EFI/TDX/TDX-SEAM.so
- <ESP>/EFI/TDX/TDX-SEAM.so.sigstruct

Check the updated TDX module information.

```
# It will display a string including version information of tdx module, such as  
major version, minor version, build date, etc.  
  
$ sudo cat /sys/firmware/tdx/tdx_module/*  
0x00000000202302060x000001c90x000000010x00000000initialized0x00008086
```

## 6.2 Off-TD Debug via GDB from the Host

QEMU supports working with gdb via gdb's remote-connection facility (the "gdbstub"). This allows you to debug guest code in the same way that you might do with a low-level debug facility like JTAG on real hardware. You can stop and start the virtual machine, examine states like registers and memory, and set breakpoints and watchpoints. Refer to <https://www.QEMU.org/docs/master/system/gdb.html> for detailed gdb usage.

To support gdb the Intel TDX module exposes the following APIs:

- TDH.VP.RD/WR to allow QEMU emulator to read/write guest's CPU states.
- TDH.MEM.RD/WR to allow QEMU emulator to read/write guest memory.

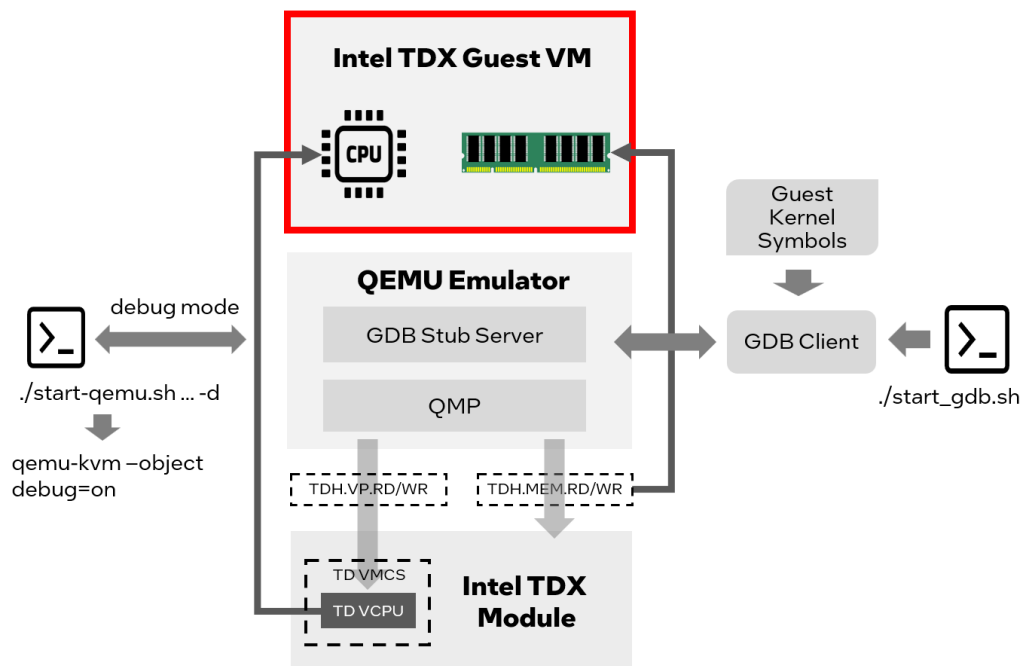

Figure 33: Off-TD Debug via GDB

Steps to debug TD guest are as follows:

- Step 1: Start TD guest in debug mode
  - Append "debug=on" to "-object". For example:

```
-object tdx-guest,id=tdx,debug=on
```

- Add -s -S parameter to qemu-kvm. For example:

```
$ qemu-kvm -s -S
```

- Disable kernel address randomization by append "nokaslr"

- If booting TD via start-qemu.sh, please refer to below command to set “debug=on”:

```
$ ./start-qemu.sh -i <guest image> -k <guest kernel> -d
```

- Step 2: Install the guest kernel’s debug symbol into the host.

```
$ sudo dnf install intel-mvp-tdx-guest-kernel-debuginfo
```

- Step 3: Run the script start\_gdb.sh with the following content.

```
#!/bin/bash
GDB=gdb
MOD_DIR=/usr/lib/debug/usr/lib/modules/<guest kernel>/
$GDB \
-ex "add-auto-load-safe-path $MOD_DIR" \
-ex "file $MOD_DIR/vmlinux" \
-ex "set arch i386:x86-64:intel" \
-ex "set remotetimeout 360" \
-ex "target remote 127.0.0.1:1234"
```

- Step 4: In the GDB console, use command “hb” to set the first break point.

```
gdb> hb start_kernel
```

The software breakpoint is available after the kernel is loaded into Guest Physical Address (GPA) space by QEMU.

## 6.3 Check Memory Encryption

There are lots of approaches to check whether TDX memory is encrypted or not. This section introduces how to do this check via a GDB debug approach.

1. Install the kernel development package on the host for debug symbols (using RHEL distro as example):

```
$ sudo dnf install intel-mvp-tdx-kernel-devel
```

2. Get the GVA (guest virtual address) of the `.text` code section of guest kernel.

```
$ # Extract the guest kernel binary
$ /usr/src/kernels/$(uname -r)/scripts/extract-vmlinux <path-to-guest-kernel-file > vmlinux
$ objdump -d vmlinux > disassembled-vmlinux.asm && head -n 20 disassembled-vmlinux.asm
...
ffffffff81000000 <.text>:
ffffffff81000000: 48 8d 25 51 3f c0 01   lea  0x1c03f51(%rip),%rsp
ffffffff81000007: 48 8d 3d f2 ff ff ff   lea  -0xe(%rip),%rdi
ffffffff8100000e: 56                     push %rsi
ffffffff8100000f: e8 dc 06 00 00        callq 0xffffffff810006f0
...
```

The result shows that the virtual address of `.text` section starts from `0xffffffff81000000`.

3. Verify the instructions/memory at the guest physical address of the `.text` code section in a non-confidential VM guest.
  - Launch a non-confidential guest, `nokaslr` should be appended for kernel command like below to turn off the Kernel Address Space Layout Randomization (KASLR).

```
-append "root=/dev/vda1 console=hvc0 nokaslr"
```

- Enter QEMU monitor shell

If using `start-qemu.sh`, just `"telnet 127.0.0.1 9001"`

- Disassemble the virtual address of the `.text` section

```
(QEMU) stop
(QEMU) x /10i 0xffffffff81000000
0x01000000: 48 8d 25 51 3f c0 01   leaq  0x1c03f51(%rip), %rsp
0x01000007: 48 8d 3d f2 ff ff ff   leaq  -0xe(%rip), %rdi
0x0100000e: 56                     pushq %rsi
0x0100000f: e8 dc 06 00 00        callq 0x10006f0
```

4. Verify the instructions/memory at guest physical address of .text code section in a TD guest.

- Launch a TD guest
  - `debug=on` should be appended for QEMU command line

```
-object tdx-guest,id=tdx,debug=on
```

- `nokaslr` should be appended for kernel command line

```
-append "root=/dev/vda1 console=hvc0 nokaslr"
```

- Enter QEMU monitor shell

If using `start-QEMU.sh`, just “`telnet 127.0.0.1 9001`”

- Disassemble the virtual address of .text section

```
(QEMU) stop
(QEMU) x /10i 0xffffffff81000000
0xffffffff81000000: 98                cwtl
0xffffffff81000001: f8                clc
0xffffffff81000002: 49 5e            popq    %r14
0xffffffff81000004: 5a                popq    %rdx
0xffffffff81000005: 55                pushq   %rbp
...
```

The disassembled instructions should be different from a non-confidential guest and should look meaningless (all zero) since the memory is encrypted.

## 6.4 Run Intel AMX workload within TDX Guest

Intel AMX is a new built-in accelerator that improves the performance of deep-learning training and inference on the CPU. This is ideal for workloads like natural-language processing, recommendation systems, and image recognition.<sup>13</sup> It is available on the 4th Gen Intel® Xeon® Scalable processors. Use the following approach to check its capability on the host server and TD guest.

```
$ grep -o amx /proc/cpuinfo
```

Expect to see output of several "amx". Empty results mean Intel AMX is not enabled.

This section introduces how to run AI workload boosted by Intel AMX within an Intel TDX guest. This offers another layer of security over traditional VM's to protect the model data while it is being used.

- Install the Intel® Optimization for TensorFlow\* version 2.8.0 via pip. Python versions supported are 3.7, 3.8, 3.9, 3.10. For TensorFlow versions 1.13, 1.14

<sup>13</sup> [Intel® Advanced Matrix Extensions Overview](#)

and 1.15 with pip > 20.0, if you get an “invalid wheel error”, try to downgrade the pip version to < 20.0

```
$ dnf install python3
$ python -m pip3 install intel-tensorflow-avx512==2.8.0
```

- Download a pre-trained model.

```
$ wget https://storage.googleapis.com/intel-optimized-tensorflow/models/v1_8/mobilenet_v1_1.0_224_frozen.pb
```

- Clone the intelai/models repo and then navigate to the benchmark directory.

```
$ dnf install git
$ git clone https://github.com/IntelAI/models.git cd models/benchmarks
```

- Intel® Optimization for TensorFlow uses Intel® oneAPI Deep Neural Network Library (oneDNN) and OpenMP library. The DNNL\_MAX\_CPU\_ISA environment variable can be used to limit processor features for oneDNN, it should be set to AVX512\_CORE\_AMX to use AMX features. The OMP\_NUM\_THREADS and KMP\_AFFINITY environment variables set the number of threads and thread affinity for OpenMP library. Set these environment variables.

```
$ export DNNL_MAX_CPU_ISA=AVX512_CORE_AMX
$ export OMP_NUM_THREADS=16
$ export KMP_AFFINITY=granularity=fine,verbose,compact
```

- Run online inference. Replace <PATH> to the absolute path where the pre-trained model is located.

```
$ python3 launch_benchmark.py \
--benchmark-only --framework tensorflow --model-name mobilenet_v1 \
--mode inference --precision bfloat16 --batch-size 1 \
--in-graph /opt/mobilenet_v1_1.0_224_frozen.pb \
--num-intra-threads 16 --num-inter-threads 1 --verbose --\ input_height=224
input_width=224 warmup_steps=20 steps=20 \ input_layer='input'
output_layer='MobilenetV1/Predictions/Reshape_1'
```

- The result will look like the following.

```
[Running warmup steps...]
steps = 10, 360.33539518900346 images/sec steps = 20, 349.292471685543 images/sec
[Running benchmark steps...]
steps = 10, 364.1521097412745 images/sec steps = 20, 369.8028566390407 images/sec
Average Throughput: 364.37 images/s on 20 iterations
```

If running same workload without “**export DNNL\_MAX\_CPU\_ISA=AVX512\_CORE\_AMX**”, the result will be a noticeably smaller (images/sec) because AMX is not being used to accelerate.

*NOTE: If you fail to run above commands and see a message like "If you cannot immediately regenerate your protos, some other possible workarounds are: 1. Downgrade the protobuf package to 3.20.x or lower. 2. Set `PROTOCOL_BUFFERS_PYTHON_IMPLEMENTATION=python` (but this will use pure-Python parsing and will be much slower)." you have two options. Option 1 is to upgrade the protobuf version to 3.20.0 as following:*

```
$ pip3.8 install --upgrade protobuf==3.20.0
```

*Option 2 is to set the environment variable as following*

```
$ export PROTOCOL_BUFFERS_PYTHON_IMPLEMENTATION=python
```

*Then re-run above online inference command.*

## 7 Disclaimer

---

The released components of the Linux Reference Stack for Intel TDX: Virtual Firmware (edk2/TDVF), bootloader (grub2), and the Linux kernel, are fully enabled to be run from within the Linux-based Intel TDX Guest VM to take advantage of the Intel TDX security technology for cryptographically isolating Trusted VMs from the rest of the system.

While Intel TDX removes the need for a Guest VM to trust the host and virtual machine manager (VMM), it cannot by itself protect the guest VM from host/VMM attacks that leverage existing paravirt-based communication interfaces between the host/VMM and the guest (such as MMIO, portIO, etc.). To achieve the full protection against such attacks, the Guest VM SW stack needs to be hardened to securely handle a untrusted and potentially malicious input from a host/VMM via the above-mentioned interfaces. This hardening effort is not specific to Intel TDX as a technology, but common for all confidential cloud computing solutions and the components of the VM guest SW stack. It should be an industry-wide effort together with the open-source maintainers to perform the security analysis and hardening of these components for the confidential computing threat model.

The Linux Reference Stack for Intel TDX team has invested a significant effort in hardening the Linux kernel that is released as part of the Linux Reference Stack for Intel TDX, the threat model for the Linux guest kernel, as well as the implemented mitigation mechanisms are explained in the Intel TDE Linux guest kernel security specification. The overall hardening methodology, as well as documentation on the tools that have been used can be found in Intel TDE guest Linux kernel hardening strategy. As a result, the Linux Reference Stack for Intel TDX kernel tree contains numerous patches that either implement these hardening mechanisms or fix the security issues that were discovered during the hardening process. It is strongly recommended that all these patches are manually carried forward to the intended production kernels, until they are merged into the mainline Linux kernel and will become part of the upstream base kernel tree. In particular, the following two patches that are critical for the security of the Intel TDX Linux guest kernel must be included in any production guest kernel:

Commit ID:

- c942fc241d4e6c215731b6f03740b1a8bfc42018 from patches-tdx-kernelMVP-KERNEL-5.19-v2.4.tar.gz



- Commit ID: c289330c56c61508a1008d74fc65b7bc24a4a7d5 from patches-tdx-kernelMVP-KERNEL-5.19-v2.4.tar.gz

It is important to note that the hardening of the Linux guest kernel has not been finalized for this release and other components, such as virtual firmware (edk2/TDVF) and the bootloader (grub2), still need more attention. In particular, the existing interfaces that edk2/TDVF or grub2 expose towards the host/VMM have not yet been analyzed for potential security implications against the confidential cloud computing threat model. It is strongly recommended that this analysis be done, and any issues uncovered are mitigated before these components are used in production.

## 8 References

---

- [1] Intel, "Intel® TDX White Papers," February 2023. [Online]. Available: <https://www.intel.com/content/www/us/en/developer/articles/technical/intel-trust-domain-extensions.html>.
- [2] Intel, "TDX Guest Hardening," [Online]. Available: <https://intel.github.io/ccc-linux-guest-hardening-docs/tdx-guest-hardening.html>.
- [3] Confidential Computing Consortium, "A Technical Analysis of Confidential Computing," 2022.
- [4] Trust Computing Group, TCG Guidance on Integrity Measurements and Event Log, 2021.